



Antibiotic Resistance

Table of Contents

Table of Contents	1
Overview	2
Chip Design	3
Milling Guidelines	4
Milling Guidelines	4
Notes	4
Milling Instructions	5
Flow Layer	5
Control Layer	5
Testing Protocol	6
Flow Layer Setup	6
Testing the Chip	7
Setup	7
Running the chip	7
Cleaning the Chip	7

Overview

Antibiotic Resistance

Designed by Dylan Samperi

Date Completed: 10/15/2017

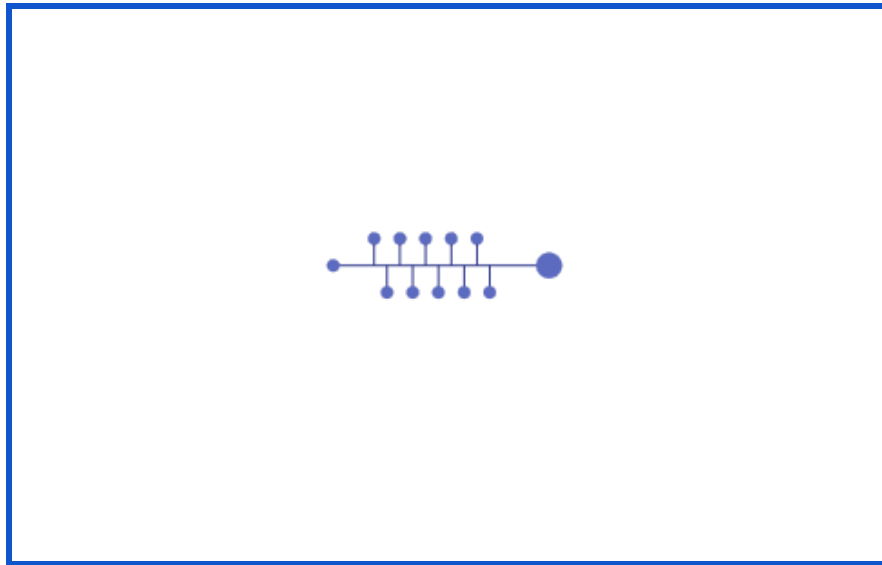

Antibiotic resistance is an important part of evaluating the success of a synthetic biology experiment. This test is usually performed after transforming your plasmid into your chassis organism. The resistance is due to selection markers that are placed within the plasmid that contains your biological part(s). The cells that were not transformed properly will die to their lack of resistance. The remaining cells can be utilized to perform subsequent experiments.

This microfluidic chip is designed to perform antibiotic resistance testing. This chip was a replicated from the publication: A self-loading microfluidic device for determining the minimum inhibitory concentration of antibiotics¹. All procedures and designs were based on this paper. The side chambers will contain varying amount of dried antibiotic. The suspended cells introduced through one of the input ports and will drive to the chambers by a vacuum.

¹ DOI: 10.1039/c2lc20887c

Chip Design

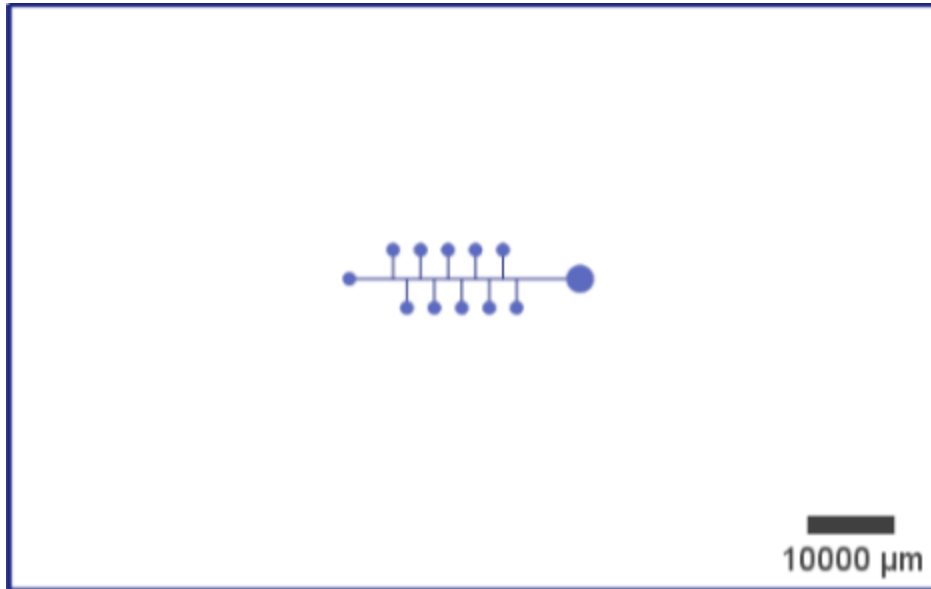
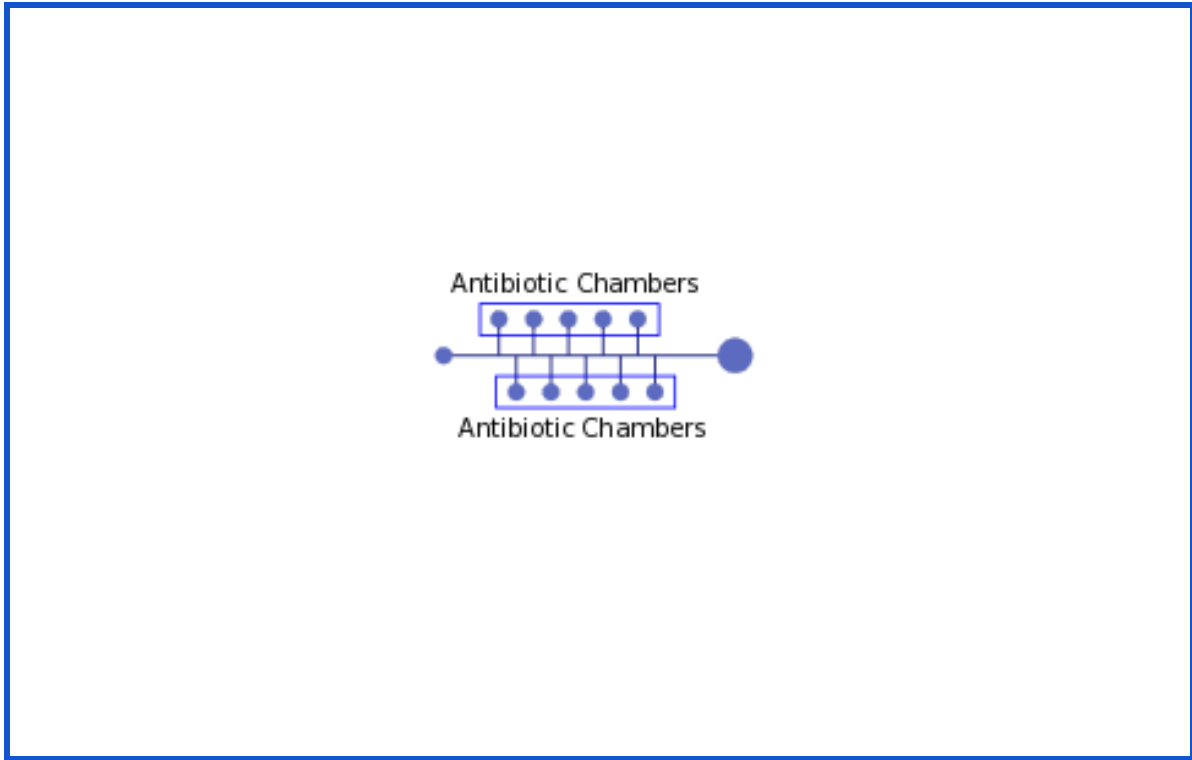

Flow Layer

Milling Guidelines

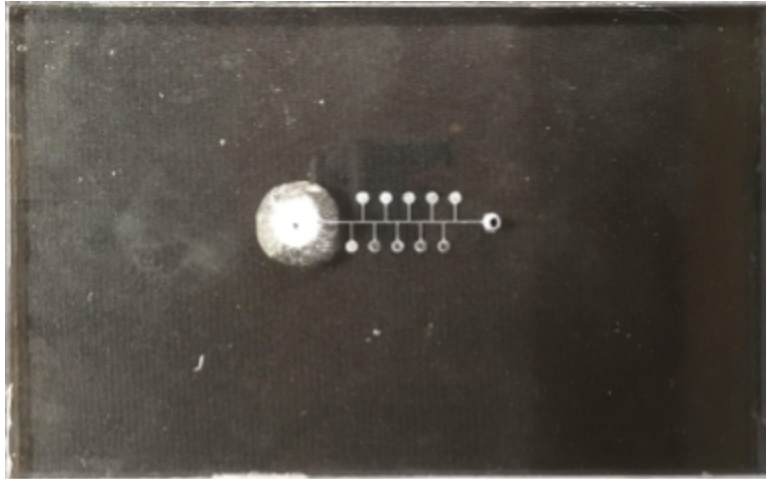

Flow Layer

Milling Guidelines

For a comprehensive guide to milling click [here](#). For a list of tool parameters click [here](#).

Notes

1. This chip should be milled on thick polycarbonate ($5.00\text{mm} < Z_{\text{Polycarbonate}}$).
2. This chip requires thin PDMS ($0.24\text{mm} < Z_{\text{PDMS}} < 0.26\text{mm}$)

All the required SVGs for milling this chip are provided in the ZIP file. The layer, depth, and tool required for each SVG is listed in the file name. Below is a key describing how to read an SVG file name:

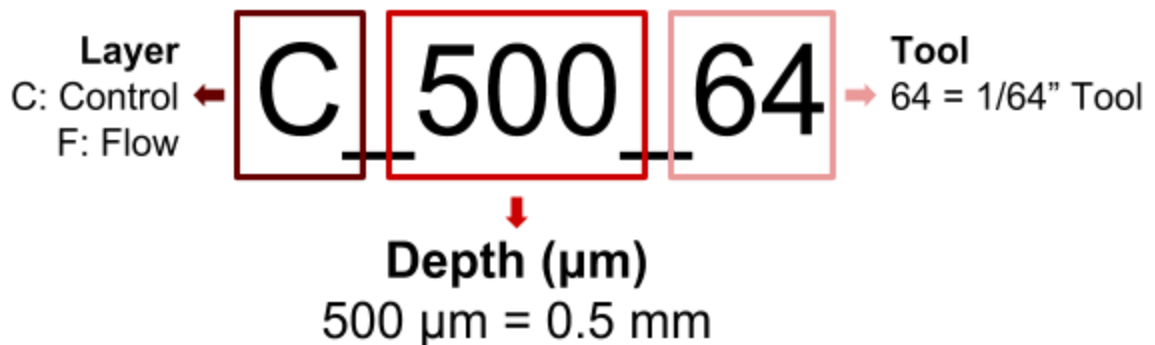

Milling Instructions

Mill the layers in the order they are listed with the correct depths and using the correct tools.

Flow Layer	
Order	Layer Name
1.	F_100_64
2.	F_300_16
3.	F_PORTS_32
4.	F_PORTS_8
5.	Border

Testing Protocol

Flow Layer Setup

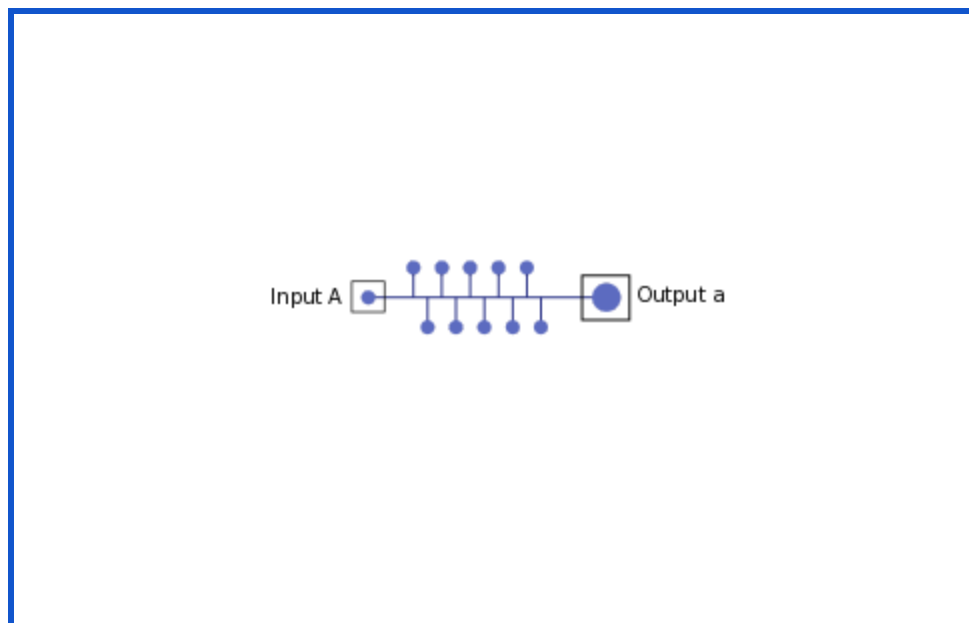

Inputs		
Name	Liquid	Flow Rate
A	Suspended Cells	-

Outputs	
Name	Liquid
a	Excess Fluid

Testing the Chip

Setup

1. Prepare 3 syringes
 - a. 1 filled with suspended cells
 - b. 1 filled with antibiotic
 - c. 1 empty
2. Dispense varying volumes of antibiotic into empty antibiotic chambers
3. Allow antibiotic to evaporate
4. Attach empty syringe to output a
5. Dispense volume of suspended cells into input A
6. Attach empty syringe to output a

Running the chip

7. Apply vacuum at output a using the empty syringe. This will drive the suspended cells at input A into the empty antibiotic chambers.
8. Collect all excess dispensed fluid in your designated receptacle

Cleaning the Chip

9. Disconnect your output tubing carefully and dispose of all liquid waste in the correct receptacle
10. Disconnect all other syringes
11. Clean the chip following the water and oil cleaning protocol listed [here](#)
12. Store your chip as detailed in the cleaning protocol