



# Transformation

## Table of Contents

<b>Table of Contents</b>	<b>1</b>
<b>Overview</b>	<b>2</b>
<b>Chip Design</b>	<b>3</b>
<b>Milling Guidelines</b>	<b>4</b>
Milling Guidelines	4
Notes	4
Milling Instructions	5
Flow Layer	5
Control Layer	5
<b>Testing Protocol</b>	<b>6</b>
Flow Layer Setup	6
Control Layer Setup	7
Testing the Chip	8
Setup	8
Running the chip	8
Cleaning the Chip	9

# Overview

## Transformation

Designed by Sarah Nemsick

Date Completed: 10/5/2017

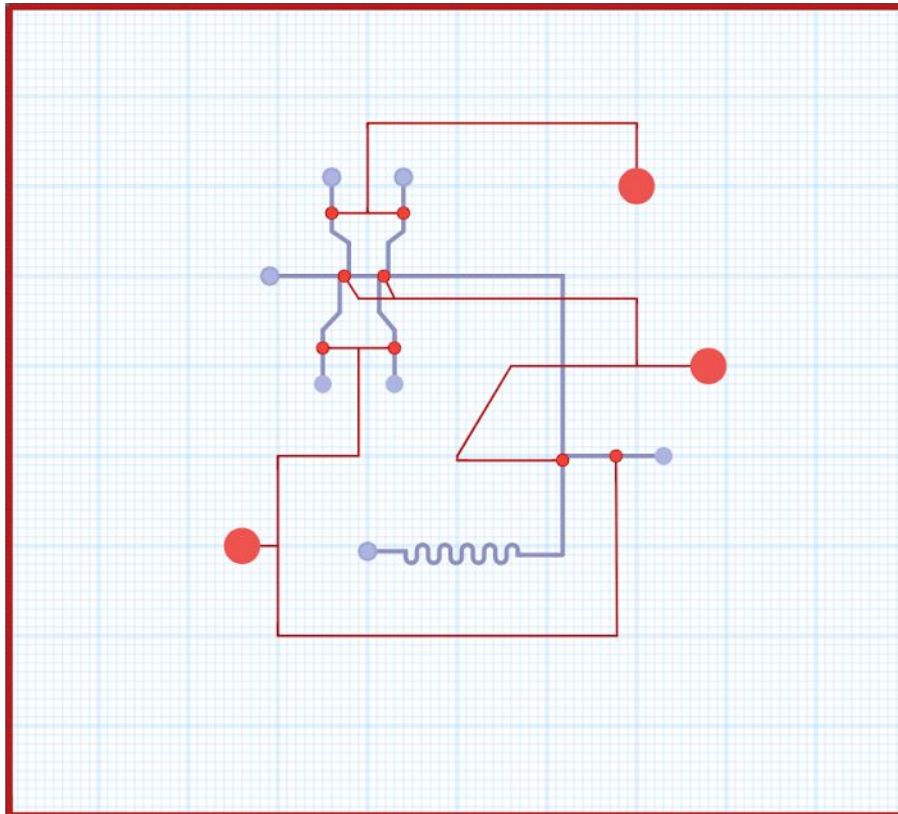

Bacterial transformation is a commonly used protocol in synthetic biology. It can be used for a variety of functions, such as testing whether or not a genetic circuit is functional.

Transformation allows bacterial cells, such as *Escherichia coli*, to take in and express external DNA fragments. Transformation consists of heat shock to damage cells and promote the taking up of external plasmids, recovery to prevent cells from dying, and a final culturing. From there, cells are analyzed.

This microfluidic chip is designed to perform transformation. Suspended cells and plasmid are metered on the chip and are then mixed together. The solution then undergoes heat shock in a time-dependent mixing element for exactly 30 seconds. The solution can then be pipetted out from the chip into a recovery tube on ice.

# Chip Design

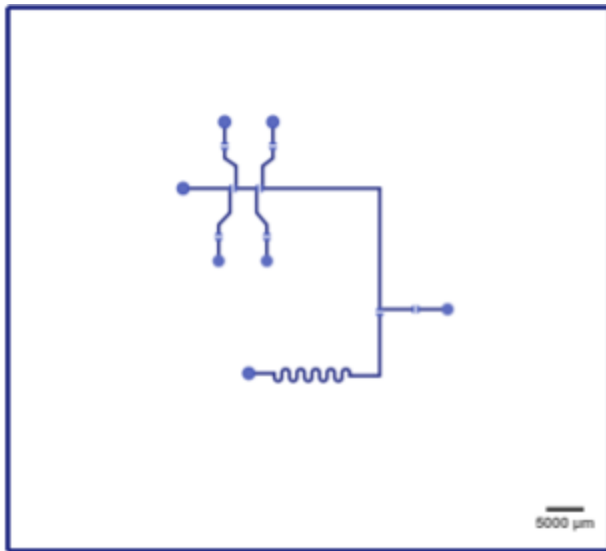
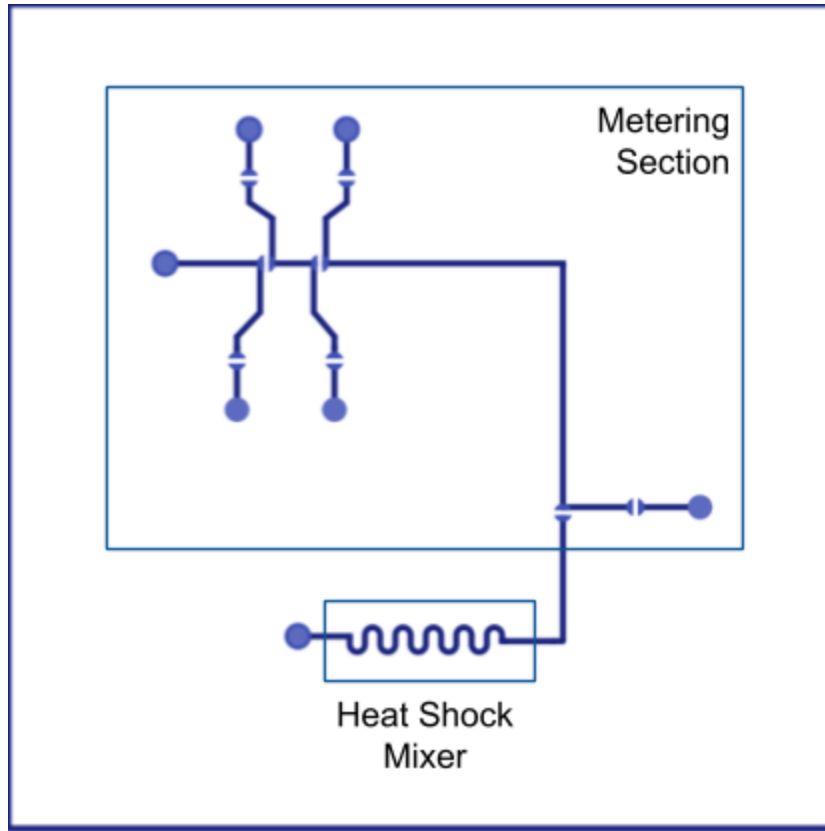

**Flow Layer**

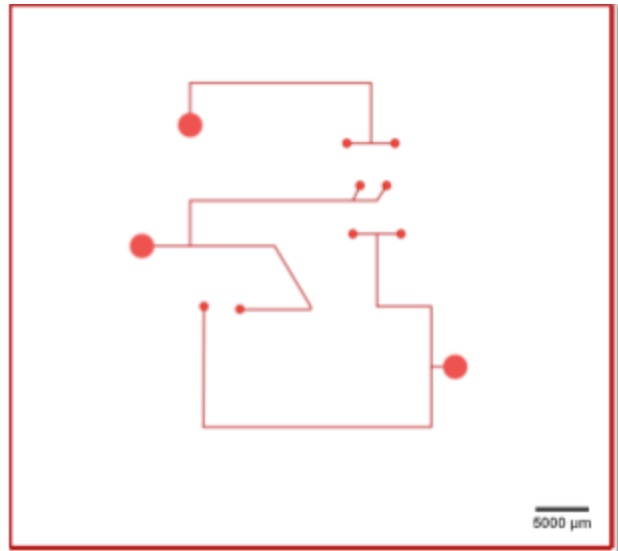

**Control Layer**

# Milling Guidelines

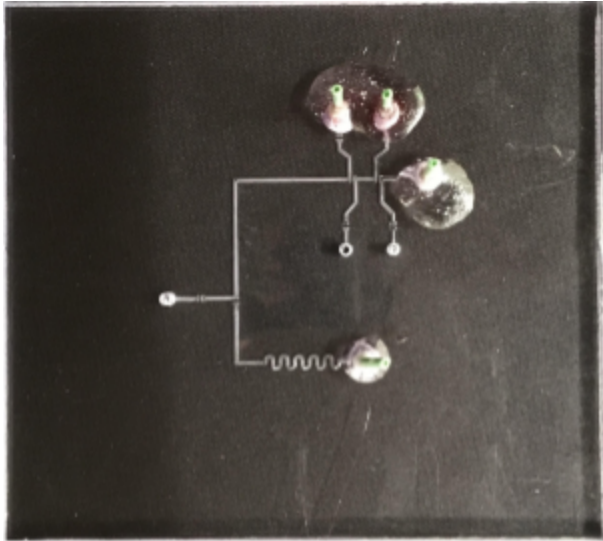

**Flow Layer**

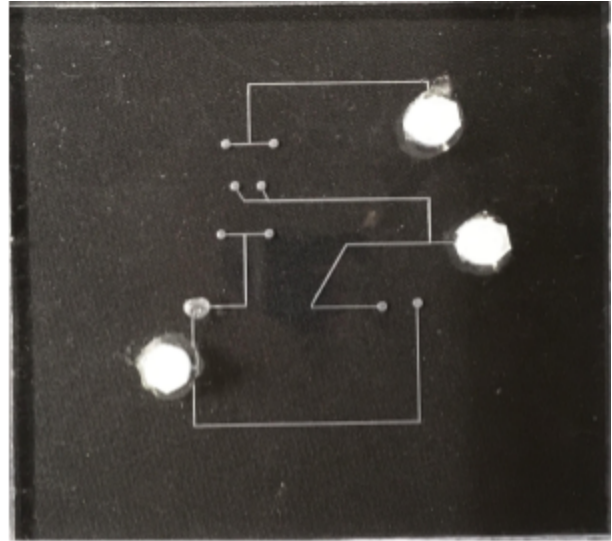

**Control Layer**

## Milling Guidelines

For a comprehensive guide to milling click [here](#). For a list of tool parameters click [here](#).

### Notes

1. This chip should be milled on thick polycarbonate ( $5.00\text{mm} < Z_{\text{Polycarbonate}}$ ).
2. This chip requires thin PDMS ( $0.24\text{mm} < Z_{\text{PDMS}} < 0.26\text{mm}$ )

All the required SVGs for milling this chip are provided in the ZIP file. The layer, depth, and tool required for each SVG is listed in the file name. Below is a key describing how to read an SVG file name:

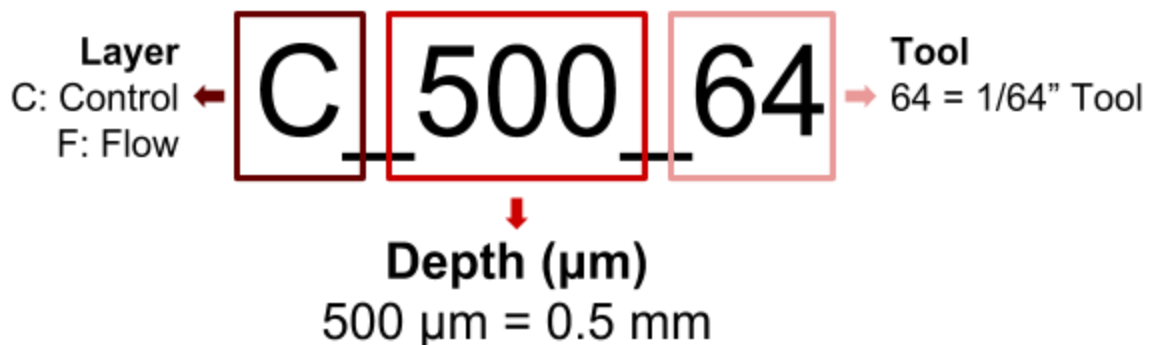

## Milling Instructions

Mill the layers in the order they are listed with the correct depths and using the correct tools.

Flow Layer	
Order	Layer Name
1.	F_500_64
2.	F_4500_16 <i>If <math>Z_{polycarbonate} &gt; 6.00 \text{ mm}</math>, <math>depth = Z_{polycarbonate} - 1000 \text{ um}</math></i>
3.	F_PORTS_16
4.	Border

Control Layer	
Order	Layer Name
1.	C_200_100
2.	C_1000_64
3.	C_PORTS_8
4.	Border

# Testing Protocol

## Flow Layer Setup

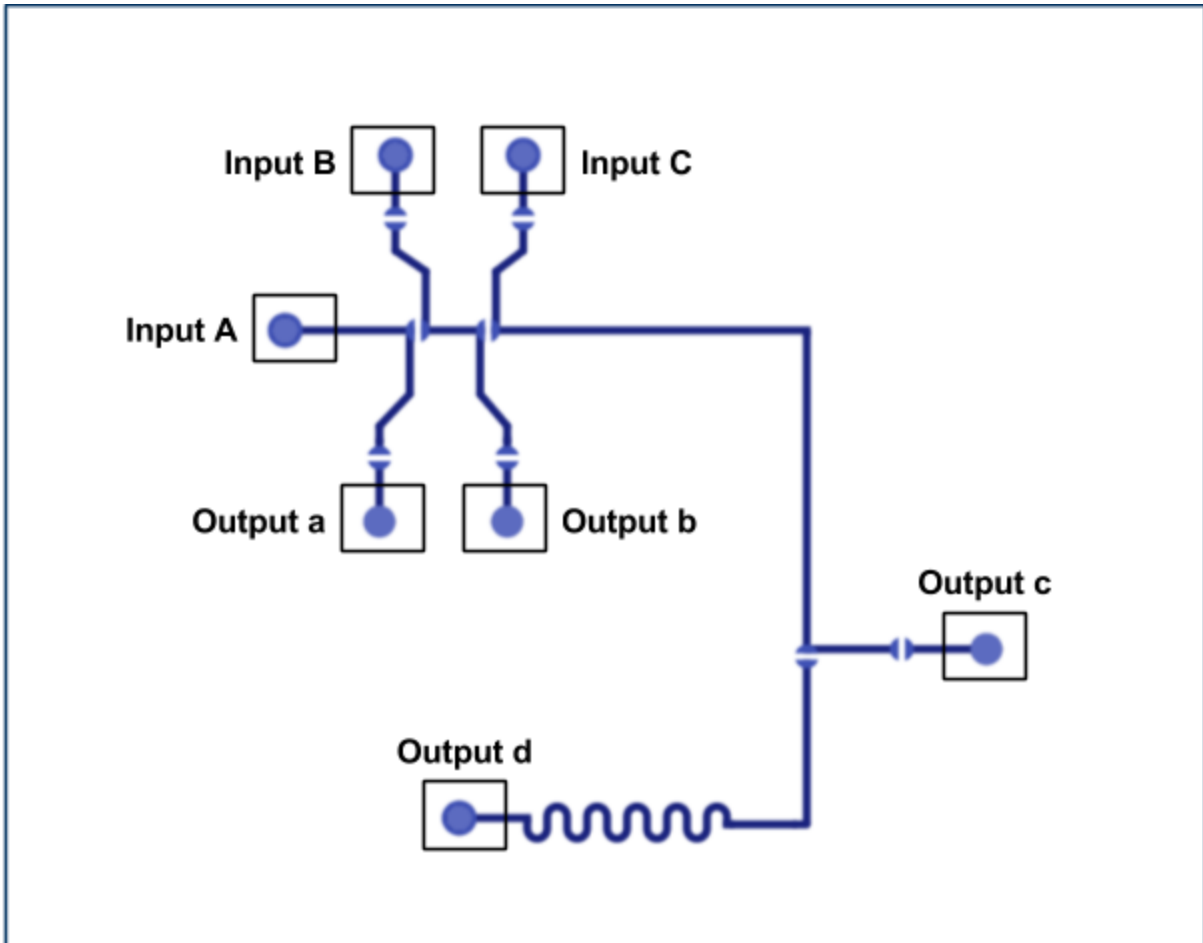

Inputs		
Name	Liquid	Flow Rate
A	Mineral Oil	0.5 mL/hour (metering) 0.835 mL/hour (pushing)
B	Plasmid <i>Represented by black colored water</i>	0.5 mL/hour
C	Cell Suspension <i>Represented by red colored water</i>	0.5 mL/hour

Outputs	
Name	Liquid
a	Excess Mineral Oil
b	Excess Plasmid
c	Excess Cell Suspension
d	Final Output

### Control Layer Setup

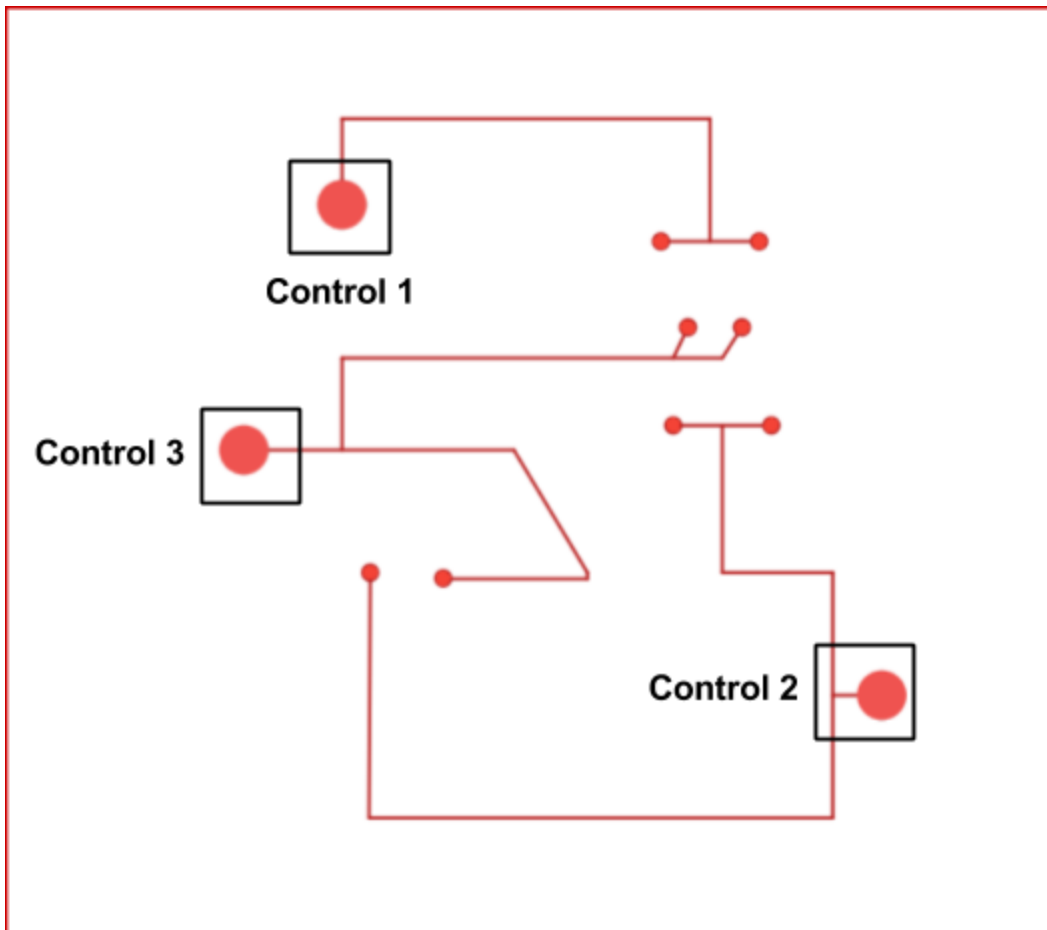

# Testing the Chip

## Setup

1. Prepare 7 syringes
  - a. 1 filled with black colored water
  - b. 1 filled with red colored water
  - c. 1 filled with mineral oil
  - d. 3 empty 3 mL control syringes
2. Attach your syringe containing mineral oil to Input A
3. Attach your syringe containing black colored water to Input B
4. Attach your syringe containing red colored water to Input C
5. Attach your waste output tubing to Outputs a, b, and c; this liquid will be excess fluid
6. Attach your output tubing to Output d; this tube should connect to an eppendorf or other small collection receptacle located in a cold water bath
7. Attach three separate control syringes to Control 1, Control 2, and Control 3
8. If a heating element is being utilized, ensure this element is turned on and at the correct temperature

## Running the chip

9. Open Control 1, then Control 2; you should feel significant resistance while you open these control valves
10. Begin flowing your mineral oil, black colored water, and red colored water at flow rates of 0.5 mL/hour each

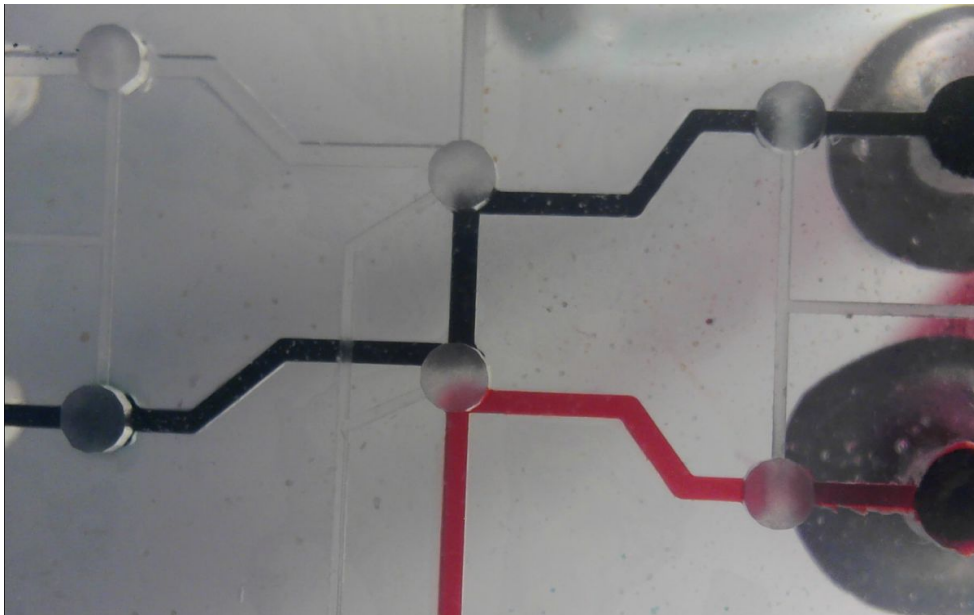

*Figure 1: Liquids filling up the metering section*



11. Once the mineral oil, red colored water, and blue colored water have filled their metering sections and have begun filling the output port, ensure all of their syringe pumps have been turned off
12. Close Control 1, pause, then close Control 2
13. Open Control 3
14. Flow the mineral oil again at 0.835 mL/hour
15. The oil will push and mix the two colored waters

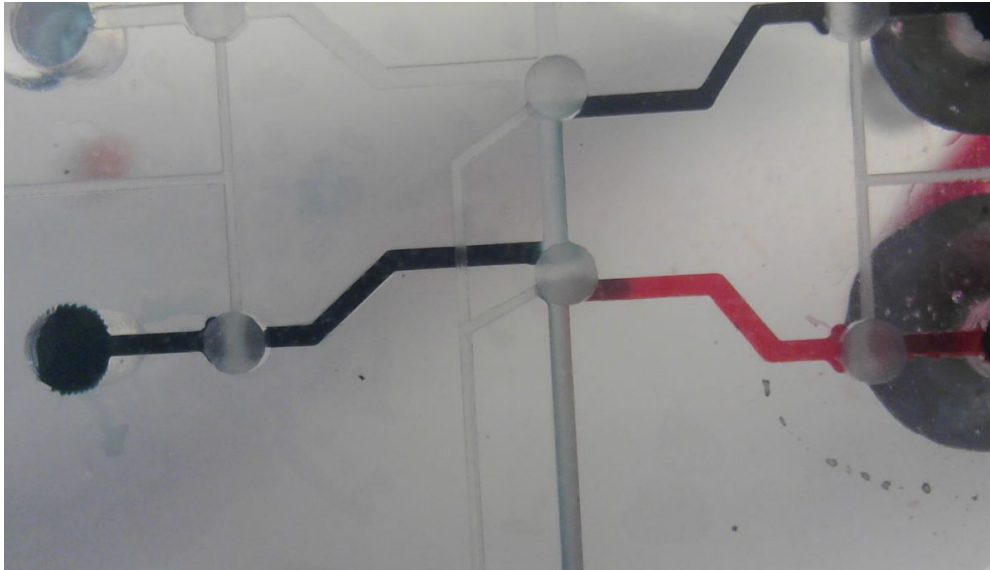

*Figure 2: Pushing & Mixing of metered liquids*

16. Collect all of the output colored liquid in your designated receptacle

### Cleaning the Chip

17. Disconnect your output tubing carefully and dispose of all liquid waste in the correct receptacle
18. Disconnect all other syringes
19. Clean the chip following the water and oil cleaning protocol listed [here](#)
20. Store your chip as detailed in the cleaning protocol