

Permanent Media Systems

2596
MCS
MCF

DCF
F-Series
AFR

AFC
Control Systems
Media

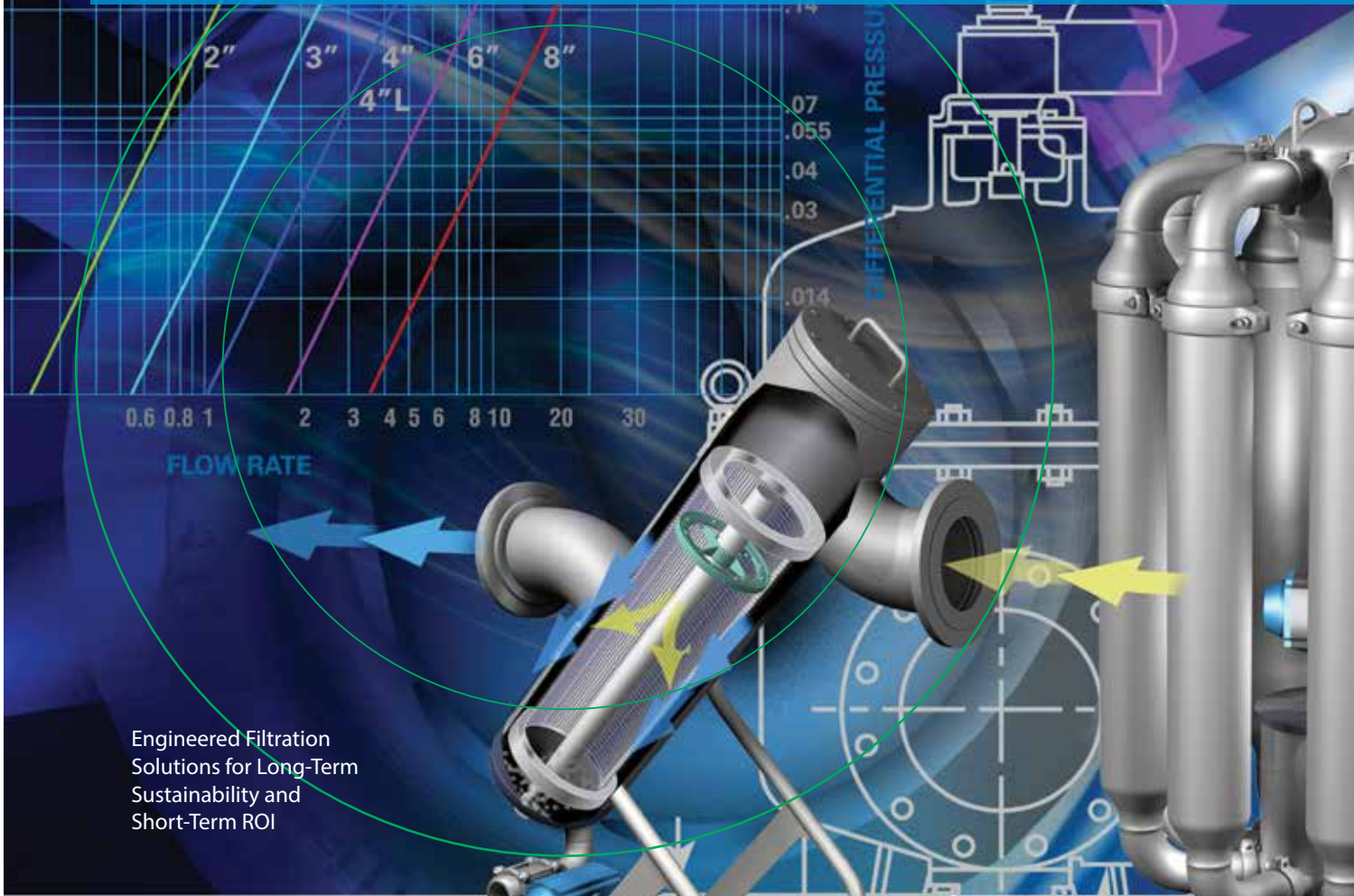

Engineered Filtration
Solutions for Long-Term
Sustainability and
Short-Term ROI

Automatic Self-Cleaning Family

EATON

Powering Business Worldwide



Eaton's Filtration business is a global leader in manufacturing filtration products that include automatic self-cleaning and fabricated pipeline strainers, mechanically cleaned filters and strainers, bag and cartridge filtration systems, and gas/liquid separators for industrial customers worldwide. Headquartered in Iselin, New Jersey, Eaton has engineering, along with research and development centers in Portage, Michigan; Sint Niklaas, Belgium; Nettersheim, Germany; and Jining, China. Sales and service centers are located in 11 countries.

Eaton supplies high-quality systems, parts, and services to markets that include automotive, food and beverage, ethanol and biofuels, oil and gas, pharmaceutical, power generation, pulp and paper, chemical, paints and coatings, electronics, iron and steel manufacturing, and municipal and industrial water. Eaton is well positioned in key markets and is expanding its global footprint with initiatives in the Americas, EMEA, and Asia Pacific.

Eaton's Filtration business has led the way with technology that meets the growing and rigorous demands of vital industrial sectors. Utilizing a variety of filtration technologies, Eaton has consistently implemented the best solutions available while continually striving to make a difference for customers and the environment.

EATON FILTRATION SERVICES

- State-of-the-art water testing lab facility
- Long-term or short-term equipment rental
- Field service - inspections, start-up, maintenance, repair, and replacement
- Field trials
- Extensive network of manufacturer representatives and distributors throughout North America
- Worldwide technical support in international markets
- Team of product specialists dedicated to providing application engineering

EATON TECHNOLOGIES

- Customized and modular solutions provide a full range of retention capabilities and construction materials in manual and automated designs
- ISO 9001-2008 quality management
- Standard ASME "U", "UM" Code, and CRN Stamp
- "N" stamp available
- European standards - DIN/CE/PED
- EPA compliant solutions
- Properly sized components to meet any specified flow rate and retention requirement
- NSF approved coatings
- Ultra low discharge strainer technology that offers reduced purge volumes

EATON SUSTAINABILITY COMMITMENT

Eaton is unwavering in our commitment to being sustainable by design—in the way we operate, through the design of our products, and through the energy and climate saving benefits our products deliver. Eaton issues a Sustainability Report as part of its Annual Report, available on www.eaton.com.

North America
44 Apple Street
Tinton Falls, NJ 07724
Toll Free: 800 656-3344
(North America only)
Tel: +1 732 212-4700

China
No. 3, Lane 280,
Linhong Road
Changning District, 200335
Shanghai, P.R. China
Tel: +86 21 5200-0099

Europe/Africa/Middle East
Auf der Heide 2
53947 Nettersheim, Germany
Tel: +49 2486 809-0

Singapore
4 Loyang Lane #04-01/02
Singapore 508914
Tel: +65 6825-1668

Friedensstraße 41
68804 Altließheim, Germany
Tel: +49 6205 2094-0

Brazil
Rua Clark, 2061 - Macuco
13279-400 - Valinhos, Brazil
Tel: +55 11 3616-8400

An den Nahewiesen 24
55450 Langenlonsheim, Germany
Tel: +49 6704 204-0



Powering Business Worldwide

**For more information, please
email us at filtration@eaton.com
or visit www.eaton.com/filtration**

© 2017 Eaton. All rights reserved. All trademarks and registered trademarks are the property of their respective owners. All information and recommendations appearing in this brochure concerning the use of products described herein are based on tests believed to be reliable. However, it is the user's responsibility to determine the suitability for his own use of such products. Since the actual use by others is beyond our control, no guarantee, expressed or implied, is made by Eaton as to the effects of such use or the results to be obtained. Eaton assumes no liability arising out of the use by others of such products. Nor is the information herein to be construed as absolutely complete, since additional information may be necessary or desirable when particular or exceptional conditions or circumstances exist or because of applicable laws or government regulations.

US
4-2017

Automatic Self-Cleaning Family

Contents

BACKWASHING TECHNOLOGY - FILTERS AND STRAINERS

- 2596-Series Motorized Strainer - Introduction
- 2596 2"– 8" Cast Iron or Stainless Steel
- 2596 10"– 16" Cast Ductile Iron
- 2596 10"– 60" Fabricated Carbon Steel and Stainless Steel
- How it Works - "Revolutionary Arm"
- Technical Data
- Media and Control Systems



- Tubular Backwashing Series - Introduction
- AFC-Series
- F-Series
- AFR-Series
- How it Works - "Pressure Tactics"
- Cleanable Media
- Components and Options



MECHANICALLY CLEANED TECHNOLOGY - FILTERS AND STRAINERS

- Mechanically Cleaned Filters and Strainers - Introduction
- DCF-400, 800, 1600
- DCF-2000
- MCF-824 Series
- MCS-500
- MCS-1500
- How it Works - "Disc Power"
- Cleanable Media and Systems Options



Powering Business Worldwide

EATON FILTRATION MARKETS

For more than 50 years, Eaton filters and strainers have earned the confidence of thousands of satisfied users. Through innovation and design, we continue to meet the ever-growing and rigorous process demands of industrial manufacturers. In facilities around the globe, you will find Eaton filters and strainers used extensively in a variety of applications.

- Automotive
- Chemical
- Electronics
- Ethanol and Biofuels
- Food and Beverage
- Industrial and Municipal Water
- Manufacturing
- Marine
- Oil and Gas
- Paint and Coatings
- Pharmaceutical
- Power Generation
- Pulp and Paper



North America
44 Apple Street
Tinton Falls, NJ 07724
Toll Free: 800 656-3344
(North America only)
Tel: +1 732 212-4700

China
No. 3, Lane 280,
Linhong Road
Changning District, 200335
Shanghai, P.R. China
Tel: +86 21 5200-0099

Europe/Africa/Middle East
Auf der Heide 2
53947 Nettersheim, Germany
Tel: +49 2486 809-0

Singapore
4 Loyang Lane #04-01/02
Singapore 508914
Tel: +65 6825-1668

Friedensstraße 41
68804 Altlußheim, Germany
Tel: +49 6205 2094-0

Brazil
Rua Clark, 2061 - Macuco
13279-400 - Valinhos, Brazil
Tel: +55 11 3616-8400

An den Nahewiesen 24
55450 Langenlonsheim, Germany
Tel: +49 6704 204-0

**For more information, please
email us at filtration@eaton.com
or visit www.eaton.com/filtration**

© 2017 Eaton. All rights reserved. All trademarks and registered trademarks are the property of their respective owners. All information and recommendations appearing in this brochure concerning the use of products described herein are based on tests believed to be reliable. However, it is the user's responsibility to determine the suitability for his own use of such products. Since the actual use by others is beyond our control, no guarantee, expressed or implied, is made by Eaton as to the effects of such use or the results to be obtained. Eaton assumes no liability arising out of the use by others of such products. Nor is the information herein to be construed as absolutely complete, since additional information may be necessary or desirable when particular or exceptional conditions or circumstances exist or because of applicable laws or government regulations.

US
4-2017

Automatic Self-Cleaning Strainers

2596 Series

Continuous flow, simplified maintenance, and worry-free operation



MODEL 2596 -TYPICAL APPLICATIONS

- Automatic self-cleaning strainers are used to strain fresh, brackish, or salt intake water for plant services such as cooling, process, and fire protection. The strainers allow water to be recycled within the plant, reducing costs.
- Process Industry—Protect heat exchangers, pumps, valves, and spray nozzles.
- Power Industry—Pump seal protection and cooling water.
- Pulp and Paper Industry—Remove and separate bark and chips for recycling and prevent clogging of nozzles.
- Sewage and Water Treatment Plants—Strain secondary effluent prior to discharge and provide clean plant service water.
- Primary Metal Industry—Provide clean water for quenching, descaling, and blast furnace cooling.

The Eaton 2596 Automatic Self-Cleaning Strainer is a motorized strainer designed for the continuous removal of entrained solids from liquid in pipeline systems. This strainer is ideal for applications that demand uninterrupted flow, a major consideration in plant operations.

Eaton Automatic Self-Cleaning Strainers are available in the following pipe sizes, 2" to 8" cast iron or cast stainless steel, 10" to 16" cast ductile

iron and 6" to 60" fabricated carbon steel and stainless steel. Custom designs and exotic materials are available upon request. A wide range of screen designs are offered from 1/8" perf to 200 mesh.

They are used for straining cooling water from ponds, lakes or rivers, cooling towers, plant service water, boiler feed water, secondary effluent, irrigation, and municipal water intake for equipment protection.

The determining factors are the level of solids content and the ability to handle the backwash discharge flow. They are a worthwhile investment when loading is high or upset conditions occur.

These strainers also provide worry-free operation. Continuous flow is assured, even while the system is being backwashed, providing uninterrupted protection for nozzles, pumps, valves, heat exchangers, and other process equipment.

Frequent cleaning and servicing of manual strainers is costly, and if not properly done, serious disruptions to the entire piping system can occur. Eaton Automatic Self-Cleaning Strainers will significantly reduce these maintenance costs. They are ideal replacements for either simplex or duplex manual strainers.

EATON

Powering Business Worldwide

Model 2596 Automatic Self-Cleaning Strainers

MODEL 2596 FEATURES / BENEFITS

- **Quality Construction:** Eaton Automatic Self-Cleaning Strainers are designed and constructed in accordance with ASME Section VIII, Division 1. ASME Code Stamp is available. Seismic qualification is also available.
- **idL™ Seal:** The unique Eaton idL Shaft Seal prevents troublesome leakage. This special quad seal means that the strainer always stays dry and clean in service with no process media leaking down the sides of the strainer.
- **Ease of Maintenance:** Unitized modular assembly—the motor, gear reducer, cover, and complete internal operating mechanism lift off as a unit, making all components easily accessible. This greatly simplifies maintenance and reduces costs.
- **Low Backwash Fluid Requirements:** Only a small portion of system flow is used during backwash due to the efficient hydraulic design.
- **Choice of Screen Elements:** DuraWedge®, Perforated, or Mesh elements.
- **Minimal Power Consumption:** 1/4 HP drive motor in 2" through 16", 1/3 HP in 18" through 30", 1/3 HP in 30", 1 HP in 36" through 42", and 2 HP in 48".
- **No Bypass of Contaminants:** 2" to 8" element caps are epoxy sealed to screen media. O-ring seals on body cover prevent bypass around element. 10" to 60" element caps are epoxy sealed to screen media. A machined cover and body provide metal-to-metal sealing and prevents bypass around the element. For those elements whose retention is below 300 micron (60 mesh) an elastomer seal is provided on top and bottom of the element.
- **Cover Seat Design:** O-ring permits resealing without time-consuming gasket replacements and adjustment.
- **Manual Operation if Required:** Utilizing extended shaft.

MODEL 2596 APPLICATION CONSIDERATIONS

For coarse straining applications, such as raw water intakes from lakes, ponds, and streams, the convoluted perforated elements will perform well and offer the most economical unit pricing.

On applications in which pre-screening of the fluid has been performed, but finer filtering of the fluids is desired, the sinter-bonded mesh element may be selected.

On applications in which the fluid being strained encounters fibrous materials, the DuraWedge element will minimize the impact of the fibers stapling to the screen.

Debris: Cleaning the straining element is accomplished by using the pressure differential between line pressure and atmosphere. During the cleaning cycle, when the backwash valve is opened to atmosphere, a portion of the strained fluid reverses flow back across the isolated section of element, lifts off the debris, and ejects it out of the strainer.

Sticky or greasy debris are more difficult to backwash and may require longer backwash cycle durations. Sand, dirt, and pipe scale should backwash easily. The quantity of debris coming into the strainer also can be a problem. Ensure that the volume of the suspended solids does not exceed 200 ppm or 0.02 percent. If the application requires heavier loading consult Eaton.

Backwash Requirements: The quantity of fluid required to clean a straining element is dependent upon the type and quantity of debris. Under normal conditions, approximately five percent of the line flow will be used for cleaning of the straining element during the cleaning cycle. To minimize the loss of fluid through the backwash, it is recommended that a manual throttling valve be added downstream of the automated valve.

Pressure and Temperature

- Cast Iron is rated at 200 psi @ 150°F.
- Ductile Iron is rated at 150 psi @ 150°F.
- Cast Stainless Steel is rated 275 psi @ 150°F.
- Fabricated units are rated at 150 psi @ 150°F. However, other ratings are available, consult Eaton.
- The minimum operating pressure is 20 psi

Cenpeller™ Technology

A common problem in many automatic self-cleaning strainers is inefficient backwashing due to debris lodged in the strainer element.

The Model 2596 2"-8" strainer features a unique vane plate positioned at the inlet of the strainer element where it contacts the process media before it enters the element. The vane causes the incoming liquid to move in a circular motion forcing the debris to lay

up against the surface of the strainer element rather than lodging in the element's openings. Lodged debris can negatively impact the differential pressure across the strainer, resulting in a shut down of the strainer and manual cleaning of the element.

Cenpeller Technology helps prevent this situation and delivers easier and more efficient backwashing.



North America
44 Apple Street
Tinton Falls, NJ 07724
Toll Free: 800 656-3344
(North America only)
Tel: +1 732 212-4700

Europe/Africa/Middle East
Auf der Heide 2
53947 Nettersheim, Germany
Tel: +49 2486 809-0

Friedensstraße 41
68804 Altließheim, Germany
Tel: +49 6205 2094-0

An den Nahewiesen 24
55450 Langenlonsheim, Germany
Tel: +49 6704 204-0

China
No. 3, Lane 280,
Linhong Road
Changning District, 200335
Shanghai, P.R. China
Tel: +86 21 5200-0099

Singapore
4 Loyang Lane #04-01/02
Singapore 508914
Tel: +65 6825-1668

Brazil
Rua Clark, 2061 - Macuco
13279-400 - Valinhos, Brazil
Tel: +55 11 3616-8400

For more information, please email us at filtration@eaton.com or visit www.eaton.com/filtration

© 2017 Eaton. All rights reserved. All trademarks and registered trademarks are the property of their respective owners. All information and recommendations appearing in this brochure concerning the use of products described herein are based on tests believed to be reliable. However, it is the user's responsibility to determine the suitability for his own use of such products. Since the actual use by others is beyond our control, no guarantee, expressed or implied, is made by Eaton as to the effects of such use or the results to be obtained. Eaton assumes no liability arising out of the use by others of such products. Nor is the information herein to be construed as absolutely complete, since additional information may be necessary or desirable when particular or exceptional conditions or circumstances exist or because of applicable laws or government regulations.

Automatic Self-Cleaning Strainers

2596 2"-8"

Pipeline
Strainer

Cast
Construction

Permanent
Media

Eaton's Model 2596 Automatic Self-cleaning Cast Pipeline Strainers are available in 2", 3", 4", 6", and 8" sizes. A 4"L size is also available which allows for greater flow rates. The Model 2596 is recognized across industries for its continuous flow, simplified maintenance, and worry-free operation.



FEATURES / BENEFITS

- Flow rates up to 1800 gpm (409 m³/hr)
- A broad selection of screen options
- Automatic backwashing for operator-free service and minimal backwash effluent
- Exclusive idL™ Seal for leak free service
- Unitized modular assembly for easy maintenance
- Cenpeller technology for more efficient and complete backwashing
- Cast iron or stainless steel construction
- High-efficiency motor

OPTIONS

25 micron and 40 micron stainless steel element with a flow rate of up to 800 gpm

The Eaton Model 2596 Automatic Self-cleaning Strainer is designed for the continuous removal of entrained solids from liquids in pipeline systems.

With an automated control system monitoring the strainer operation, cleaning is accomplished by an integral backwash system. A small portion of the screen element is isolated and cleaned by reverse flow while the remaining screen area continues to strain—providing uninterrupted flow. This efficient design uses only a small amount of the liquid being strained to carry debris away from the strainer element.

The Model 2596 features the idL™ shaft seal that positively prevents leakage from the backwash shaft at the top of the strainer. This unique quad seal keeps the exterior of the strainer dry and prevents

external leakage or weeping of the process media down the sides of the strainer.

The 2" to 8" size strainers feature Eaton's Cenpeller™ technology, which directs incoming liquid into a circular flow—forcing the debris to lay up against the surface of the strainer element in a way that makes backwashing easier and more efficient and greatly reduces the need for manual cleanouts.



To simplify maintenance the Model 2596 features a unitized modular assembly. The motor, gear reducer, and the internal operating mechanism are housed within the strainer cover and lift off as a unit. This makes all components easily accessible and reduces associated maintenance costs.

EATON

Powering Business Worldwide

Model 2596 2" to 8" Automatic Self-Cleaning Strainers

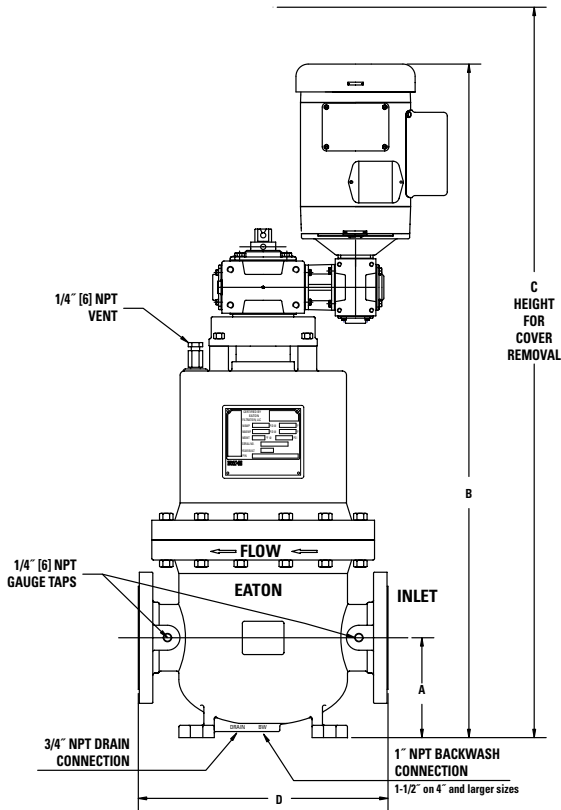

Model 2596 2" - 8" Flow Rates

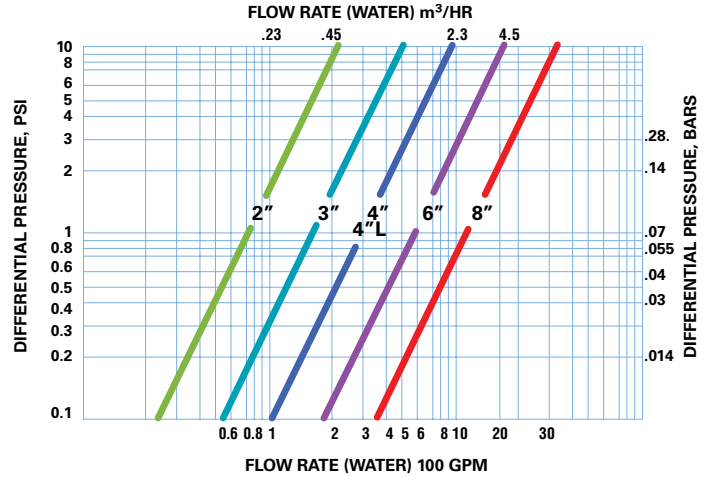

Pressure drop data indicates results to be expected with clean water, under normal flows with standard straining media and in clean strainer.

Size	Approximate Dimensions (in)				Approximate Weight (lb)		
	A	B	C	D	Dry	Wet	Cover
2"	6	40½	42½	15	328	382	164
3"	6	40½	42½	15	344	399	164
4"	7	42	44	15	353	413	164
4"L	8	52	55	23½	805	998	438
6"	8	55	58	23½	836	1081	438
8"	8	55	58	23½	901	1129	438

Dimensions are for reference only. For installation purposes, request certified drawings.

C _V Factors 25µ		C	ors 40µ	
Size	Value		Size	Value
2"	76	C	2"	77
3"	156		3"	163
4"	233		4"	260
4L"	272		4L"	288
6"	528		6"	605
8"	708		8"	887

Application Limits

- Cast Iron Class 125 Flange (-20° to 150 °F) 200 psi (2" - 8")
- Cast 316 Stainless Steel Class 150 Flange (-20° to 100 °F) 275 psi (2" - 4")
- 6" - 8" Fabricated Class 150 Flange (150 °F) 150 psi

STRAINER MEDIA

DuraWedge® Element

DuraWedge is a nonclogging, rugged stainless steel element for the most demanding applications. It is constructed from V-shaped profile wire. A wide range of opening sizes is available.



Convuluted Element

A sturdy, economical stainless steel element for general service use. Available perforated openings of 1/8", 1/16", and 1/32". Available mesh sizes of 20, 40, 60, 80, 100, 150, and 200 mesh.



Low Micron Element

Stainless steel with a high degree of permeability will substantially lower pressure differential, increase flow capacity, and extend the filter life. Sintered mesh construction prevents media migration into processed product. Available in 25µ and 40µ retention.



North America
44 Apple Street
Tinton Falls, NJ 07724
Toll Free: 800 656-3344
(North America only)
Tel: +1 732 212-4700

China
No. 3, Lane 280,
Linhong Road
Changning District, 200335
Shanghai, P.R. China
Tel: +86 21 5200-0099

Europe/Africa/Middle East
Auf der Heide 2
53947 Nettersheim, Germany
Tel: +49 2486 809-0

Singapore
4 Loyang Lane #04-01/02
Singapore 508914
Tel: +65 6825-1668

Friedensstraße 41
68804 Altlußheim, Germany
Tel: +49 6205 2094-0
An den Nahewiesen 24
55450 Langenlonsheim, Germany
Tel: +49 6704 204-0

Brazil
Rua Clark, 2061 - Macuco
13279-400 - Valinhos, Brazil
Tel: +55 11 3616-8400



Powering Business Worldwide

For more information, please
email us at filtration@eaton.com
or visit www.eaton.com/filtration

© 2017 Eaton. All rights reserved. All trademarks and registered trademarks are the property of their respective owners. All information and recommendations appearing in this brochure concerning the use of products described herein are based on tests believed to be reliable. However, it is the user's responsibility to determine the suitability for his own use of such products. Since the actual use by others is beyond our control, no guarantee, expressed or implied, is made by Eaton as to the effects of such use or the results to be obtained. Eaton assumes no liability arising out of the use by others of such products. Nor is the information herein to be construed as absolutely complete, since additional information may be necessary or desirable when particular or exceptional conditions or circumstances exist or because of applicable laws or government regulations.

US
4-2017

Automatic Self-Cleaning Strainers

2596 10"-16"

Pipeline
Strainer

Cast
Construction

Permanent
Media



Model 2596 10"

Eaton's Model 2596 Automatic Self-cleaning Cast Pipeline Strainers are available in 10", 12", 14" and 16" sizes. The Model 2596 is recognized across industries for its continuous flow, simplified maintenance, and worry-free operation.

FEATURES / BENEFITS

- Flow rates up to 6500 gpm (1476 m³/hr)
- A broad selection of screen options
- Automatic backwashing for operator-free service and minimal backwash effluent
- Exclusive idL™ Seal for leak free service
- Unitized modular assembly for easy maintenance
- Cast ductile iron construction

The Eaton Model 2596 Automatic Self-Cleaning Strainer is designed for the continuous removal of entrained solids from liquids in pipeline systems.

With an automated control system monitoring the strainer operation, cleaning is accomplished by an integral backwash system. A small portion of the screen element is isolated and cleaned by reverse flow while the remaining screen area continues to strain—providing uninterrupted flow. This efficient design uses only a small amount of the liquid being strained to carry debris away from the strainer element.

The Model 2596 features the idL™ shaft seal that positively prevents leakage from the backwash shaft at the top of the strainer. This unique quad seal keeps the exterior of the strainer dry and prevents external leakage or weeping of the process media down the sides of the strainer.

To simplify maintenance the Model 2596 features a unitized modular assembly. The motor, gear reducer, and the internal operating mechanism are all housed within the strainer cover and lift off as a unit. This makes all components easily accessible and reduces associated maintenance costs.

EATON

Powering Business Worldwide

Model 2596 10" to 16" Automatic Self-Cleaning Strainers

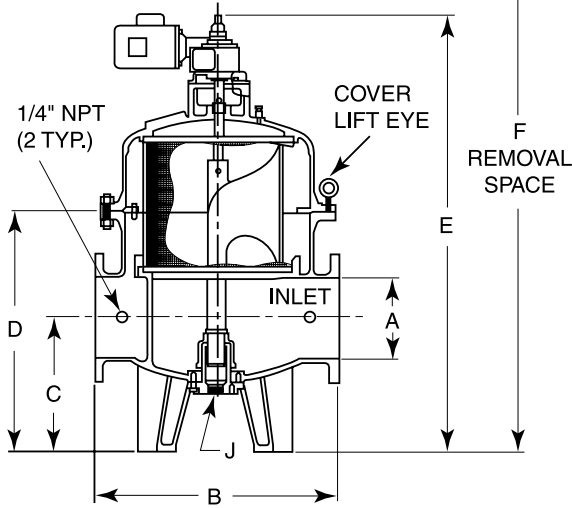
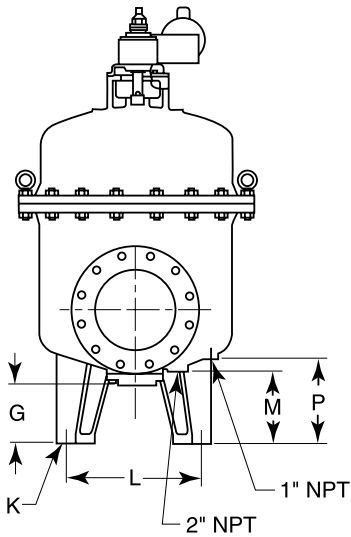

Model 2596 10" - 16" Flow Rates

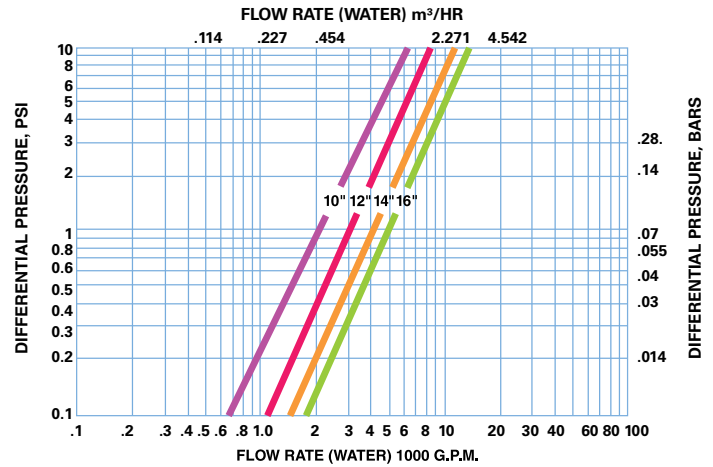

Pressure drop data indicates results to be expected with clean water, under normal flows with standard straining media and in clean strainer.

Application Limits

- Ductile Iron Class 125 Flange (-20° to 150°F) 150 psi

Application Limit 16" Size

- Ductile Iron Class 125 Flange (-20° to 150°F) 150 psi Based on ASME Section VIII, Div. 1. Lower pressure ratings at higher temperatures

Approximate Dimensions (inches)												Approximate Weight (lb)		
A	B	C	D	E	F	G	J	K	M	P	L	Dry	Wet	Cover
10"	38 1/4	19 3/4	35 3/4	64 3/4	90	8 9/16	2	7/8	10 11/16	12 1/2	24 1/2	1,840	2,615	705
12"	36 1/4	19 3/4	35 3/4	64 3/4	90	8 9/16	2	7/8	10 11/16	12 1/2	24 1/2	1,880	2,675	705
14"	44	22 1/16	42 5/16	76 1/2	112	8 9/16	2	7/8	10 7/8	13 1/2	29 5/8	2,810	4,360	1,050
16"	44	22 1/2	42 5/16	76 1/2	112	8 9/16	2	7/8	10 7/8	13 1/2	29 5/8	2,850	4,400	1,050

North America
44 Apple Street
Tinton Falls, NJ 07724
Toll Free: 800 656-3344
(North America only)
Tel: +1 732 212-4700

China
No. 3, Lane 280,
Linhong Road
Changning District, 200335
Shanghai, P.R. China
Tel: +86 21 5200-0099

Europe/Africa/Middle East
Auf der Heide 2
53947 Nettersheim, Germany
Tel: +49 2486 809-0

Singapore
4 Loyang Lane #04-01/02
Singapore 508914
Tel: +65 6825-1668

Friedensstraße 41
68804 Altlußheim, Germany
Tel: +49 6205 2094-0
An den Nahewiesen 24
55450 Langenlonsheim, Germany
Tel: +49 6704 204-0

Brazil
Rua Clark, 2061 - Macuco
13279-400 - Valinhos, Brazil
Tel: +55 11 3616-8400



For more information, please email us at filtration@eaton.com or visit www.eaton.com/filtration

© 2017 Eaton. All rights reserved. All trademarks and registered trademarks are the property of their respective owners. All information and recommendations appearing in this brochure concerning the use of products described herein are based on tests believed to be reliable. However, it is the user's responsibility to determine the suitability for his own use of such products. Since the actual use by others is beyond our control, no guarantee, expressed or implied, is made by Eaton as to the effects of such use or the results to be obtained. Eaton assumes no liability arising out of the use by others of such products. Nor is the information herein to be construed as absolutely complete, since additional information may be necessary or desirable when particular or exceptional conditions or circumstances exist or because of applicable laws or government regulations.

US
4-2017

Automatic Self-Cleaning Strainers

2596 10"-60"

Pipeline
Strainer

Fabricated
Construction

Permanent
Media

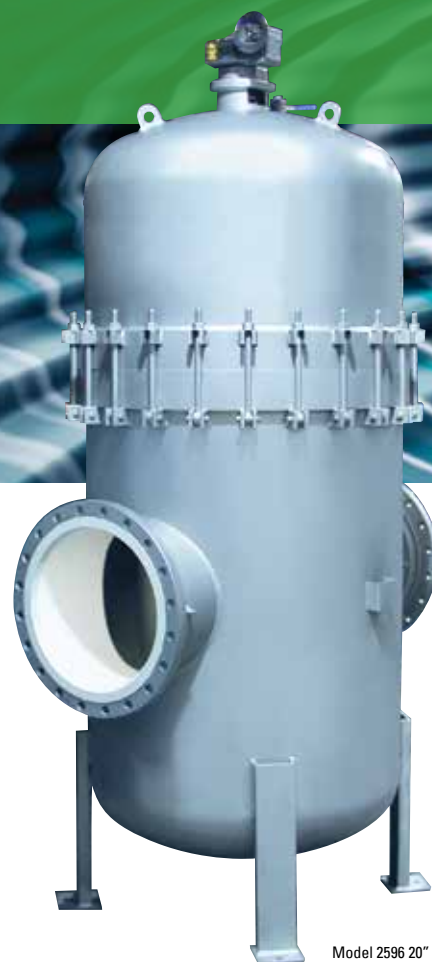

Model 2596 20"

Eaton's Model 2596 Fabricated Automatic Self-Cleaning Pipeline Strainers are available in 10", 12", 14", 16", 18", 20", 24", 30", 36", 48", and 60" sizes. Continuous flow, simplified maintenance, and worry-free operation characterize the Model 2596 across numerous industries.

FEATURES / BENEFITS

- Flow rates up to 35,000 gpm (7949 m³/hr)
- A broad selection of screen options
- Automatic backwashing for operator-free service and minimal backwash effluent
- Exclusive idL™ Seal for leak free service, available up to 24" only
- Unitized modular assembly for easy maintenance
- Fabricated carbon steel construction

OPTIONS

- Various grades of stainless steel, copper nickel, monel, and other exotic materials of construction
- ASME Section VIII, Div. 1. code stamp available.
- Flanged, screwed, or socket weld backwash connections
- Internal and external epoxy paint or other coatings, upon request, on all carbon steel components for fresh water service applications
- Custom designs are available upon request

The Eaton Model 2596 Automatic Self-Cleaning Strainer is designed for the continuous removal of entrained solids from liquids in pipeline systems.

With an automated control system monitoring the strainer operation, cleaning is accomplished by an integral backwash system. A small portion of the screen element is isolated and cleaned by reverse flow while the remaining screen area continues to strain—providing uninterrupted flow. This efficient design uses only a small amount of the liquid being strained to carry debris away from the strainer element.

The Model 2596 features the idL™ shaft seal that positively prevents leakage from the backwash shaft at the top of the strainer. This unique quad seal keeps the exterior of the strainer dry and prevents external leakage or weeping of the process media down the sides of the strainer.

To simplify maintenance the Model 2596 features a unitized modular assembly. The motor, gear reducer, and the internal operating mechanism are housed within the strainer cover and lift off as a unit. This makes all components easily accessible and reduces associated maintenance costs.

EATON

Powering Business Worldwide

Model 2596 10" to 60" Fabricated Automatic Self-Cleaning Strainers

10" to 36" Fabricated Carbon Steel and Stainless Steel

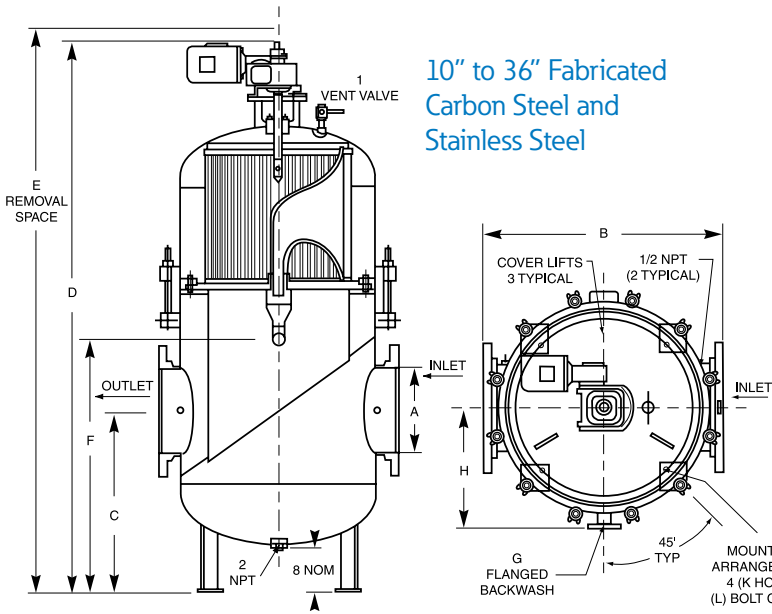

Note:

K= Diameter Bolt Hole (4) Required 90° Apart

L= Diameter Bolt Circle

Dimensions are for reference only. For installation purposes, request certified drawings.

Model 2596 10" - 36" Flow Rates

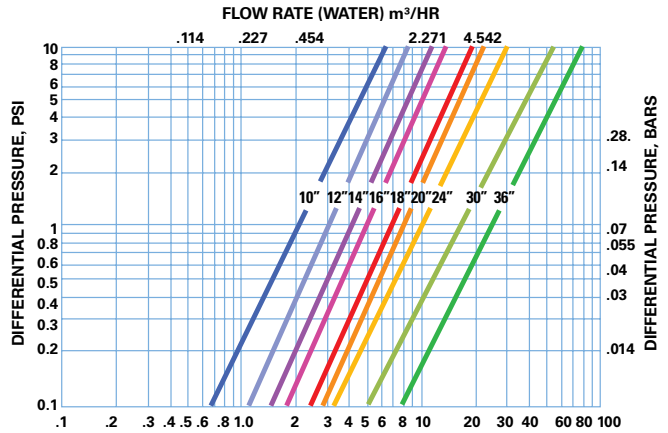

Pressure drop data indicates results to be expected with clean water, under normal flows with standard straining media and in clean strainer.

Approximate Dimensions (in)	Approximate Weight (lb)												
	A	B	C	D	E	F	G	H	K	L	Dry	Wet	Cover
10"	38	30	88	90	40	2	16	3/4	22	13/100	1,200	2,400	650
12"	42	30	88	90	40	2	18	3/4	26	13/100	1,300	2,700	700
14"	44	32	101	103	46	2	22	7/8	32	13/100	2,000	4,400	850
16"	44	33	101	103	46	2	22	7/8	32	13/100	2,050	4,450	850
18"	50	36	117	120	48	3	23	7/8	34	13/100	3,500	8,300	1,280
20"	54	37	120	123	50	3	25	7/8	38	13/100	3,700	10,000	1,480
24"	54	39	124	127	54	3	25	7/8	38	13/100	3,830	10,160	1,480
30"	64	51	147	151	76	3	30	7/8	48	13/100	5,000	13,400	2,000
36"	84	56	176	182	72	6	37	1 1/8	66		9360	24,735	4,520

48" and 60" can be fabricated upon request, consult Eaton.

Sizes 10" Thru 60"

Application Limits

- Fabricated strainers are designed within the limits of the customer's specifications and design criteria along with any applicable code requirement, i.e. ASME Section VIII Div. 1.

Specific descriptions and construction details illustrated may vary slightly from equipment furnished. We reserve the right to revise or discontinue equipment or design features without notice. We recommend that you review performance and application data with us prior to final design.

North America
44 Apple Street
Tinton Falls, NJ 07724
Toll Free: 800 656-3344
(North America only)
Tel: +1 732 212-4700

China
No. 3, Lane 280,
Linhong Road
Changning District, 200335
Shanghai, P.R. China
Tel: +86 21 5200-0099

Europe/Africa/Middle East
Auf der Heide 2
53947 Nettersheim, Germany
Tel: +49 2486 809-0

Singapore
4 Loyang Lane #04-01/02
Singapore 508914
Tel: +65 6825-1668

Friedensstraße 41
68804 Altlußheim, Germany
Tel: +49 6205 2094-0
An den Nahewiesen 24
55450 Langenlonsheim, Germany
Tel: +49 6704 204-0

Brazil
Rua Clark, 2061 - Macuco
13279-400 - Valinhos, Brazil
Tel: +55 11 3616-8400

TECHNICAL INFORMATION

Model 2596 Automatic Self-Cleaning Strainers

Revolutionary Arm

Model 2596 Strainer: How it Works

The debris-laden fluid enters the strainer's bottom chamber (1) where the line velocity is reduced. Flow continues upward, passing radially through the sealed screen element, (2) which traps debris on the inside of the screen. The flow is uninterrupted and the strained fluid flows to the outer annulus (3) and exits through the outlet nozzle (4).

Backwash cleaning is accomplished by utilizing the pressure differential between line pressure and atmosphere. A high-efficiency, full flow backwash arm (5) extending the entire length of the screen element, rotates slowly inside of the screen and is piped to atmosphere. The port shoe (6) is in proximity to the screen and its opening is equivalent to the "debris collector" sections created by the convolutions and/or vertical collector bars in the element.

When cleaning is required the automatic backwash valve opens the system to atmosphere, causing a high velocity reverse flow across the isolated section of the screen. Dirt and debris are dislodged from this segment of the screen into the backwash arm and out the strainer through the backwash piping (7). During the backwashing cycle the main flow is uninterrupted and continues to be strained in the normal manner.



Designed to monitor and operate the backwash cleaning system, Eaton automatic control systems are simple to operate, reliable, and easily maintained. They are set to clean on differential pressure with a timed backup. The design allows field adjustments to suit the demands of the service conditions, ensuring effective cleaning with a minimum use of backwash fluid. Systems are available in automatic intermittent or continuous backwashing modes.

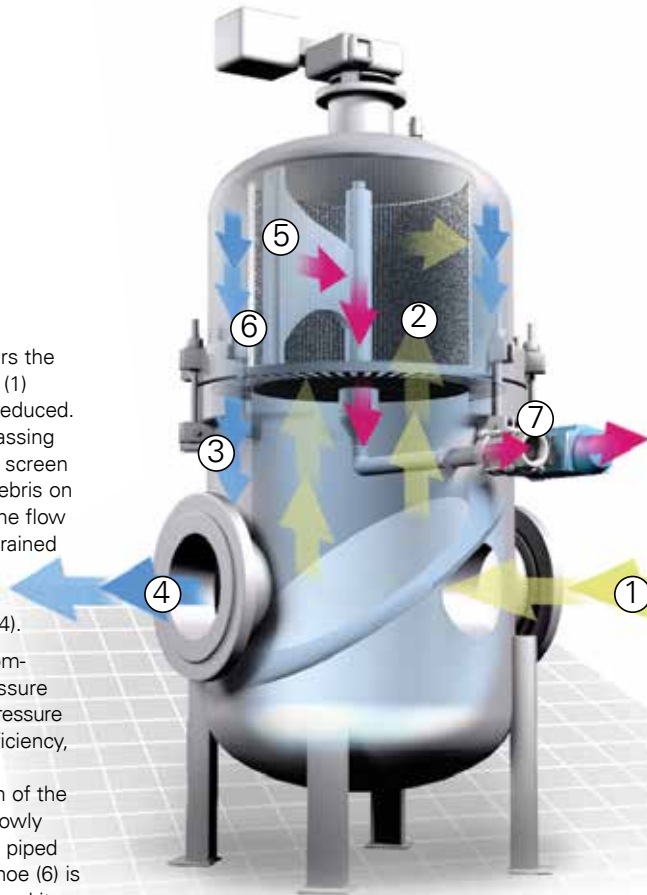

Straining Cycle

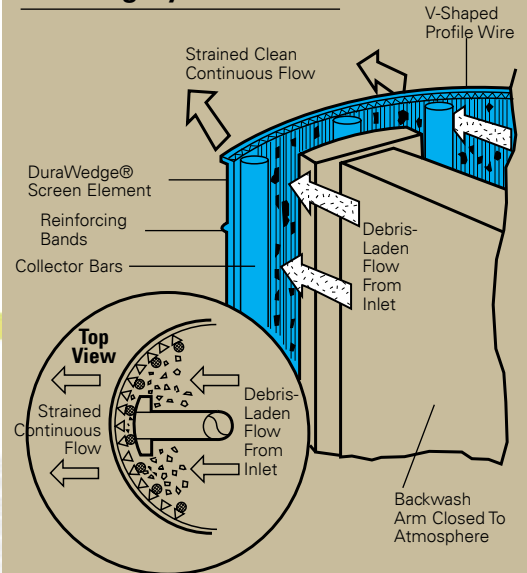

Backwashing Cycle

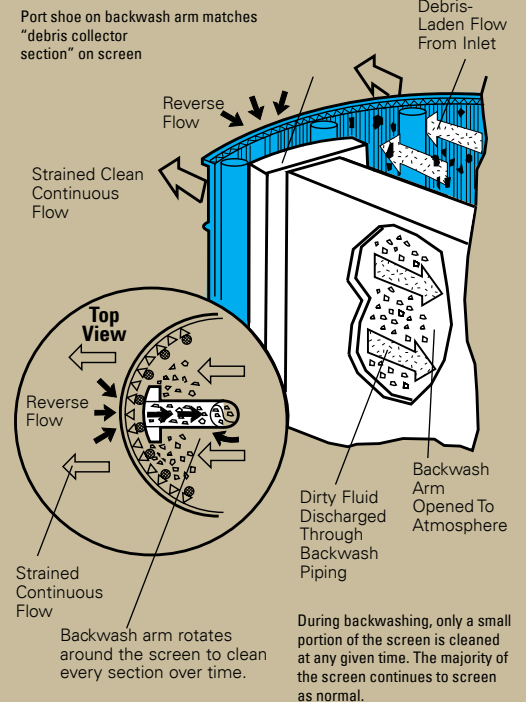

During backwashing, only a small portion of the screen is cleaned at any given time. The majority of the screen continues to screen as normal.



Powering Business Worldwide

TECHNICAL INFORMATION

Model 2596 Automatic Self-Cleaning Strainers

Sizes 2" Thru 8"
Cast Construction
Model 2596
Automatic
Self-Cleaning
Pipeline
Strainers are
available for six
different pipeline
sizes. The 4"L
size is designed
for applications
where the
combination of
flow rate and open area
requirements may be
too great for a standard
4" size. Flow rates up
to 1,800 GPM.



2596 10" to 16" Cast Metal
models provide flow rates up
to 6500 GPM.



2596 Fabricated
models are
available in eight
different sizes
from 10" to 36",
48" and 60" can
be fabricated
upon request.
Custom designs
and exotic
materials are also
available upon
request, consult
Eaton

Model 2596 Flow Rate Comparison Chart

I/O Size & Construction	GPM flow rate*
2" cast	50 - 120
3" cast	100 - 260
4"/4L" cast	170 - 450
6" cast	370 - 1000
8" cast	500 - 1800
10" cast	900 - 2800
12" cast	1200 - 4000
14" cast	1600 - 5000
16" cast	2000 - 6500
10" fabricated	900 - 2800
12" fabricated	1200 - 4000
16" fabricated	2000 - 6500
18" fabricated	2500 - 8500
20" fabricated	2900 - 10,200
24" fabricated	3200 - 15,000
30" fabricated	5000 - 24,000
36" fabricated	7800 - 35,000

* Pressure drop data is approximate and indicates results to be expected with clean water, under normal flows with standard straining media and in clean strainer. For DuraWedge and sinter bonded elements, consult Eaton

North America
44 Apple Street
Tinton Falls, NJ 07724
Toll Free: 800 656-3344
(North America only)
Tel: +1 732 212-4700

China
No. 3, Lane 280,
Linhong Road
Changning District, 200335
Shanghai, P.R. China
Tel: +86 21 5200-0099

Europe/Africa/Middle East
Auf der Heide 2
53947 Nettersheim, Germany
Tel: +49 2486 809-0

Singapore
4 Loyang Lane #04-01/02
Singapore 508914
Tel: +65 6825-1668

Friedensstraße 41
68804 Altließheim, Germany
Tel: +49 6205 2094-0

Brazil
Rua Clark, 2061 - Macuco
13279-400 - Valinhos, Brazil
Tel: +55 11 3616-8400

An den Nahewiesen 24
55450 Langenlonsheim, Germany
Tel: +49 6704 204-0



Powering Business Worldwide

**For more information, please
email us at filtration@eaton.com
or visit www.eaton.com/filtration**

US
4-2017

© 2017 Eaton. All rights reserved. All trademarks and registered trademarks are the property of their respective owners. All information and recommendations appearing in this brochure concerning the use of products described herein are based on tests believed to be reliable. However, it is the user's responsibility to determine the suitability for his own use of such products. Since the actual use by others is beyond our control, no guarantee, expressed or implied, is made by Eaton as to the effects of such use or the results to be obtained. Eaton assumes no liability arising out of the use by others of such products. Nor is the information herein to be construed as absolutely complete, since additional information may be necessary or desirable when particular or exceptional conditions or circumstances exist or because of applicable laws or government regulations.

Model 2596 Automatic Self-Cleaning Strainers

Control Systems & Elements

Eaton Automatic Control Systems (ACS) are specifically designed to monitor and operate the backwash cleaning system of Eaton Automatic Strainers. Simple to operate, reliable, and easily maintained. The design allows field adjustments to suit the demands of the service conditions, ensuring effective cleaning with a minimum use of backwash fluid.

STANDARD CONTROL SYSTEM FEATURES

ACS-1S This system features a NEMA 4 rated (water and dust tight) panel box complete with adjustable timer, display differential pressure override, 10 amp control relay for backwash valve activation, display lights to indicate Power On, Backwash Valve Open, and High Differential Pressure. A selector switch is also included to manually control the backwash valve functions of Off-On-Auto. The panel also has contact terminals for a motor starter and an external alarm connection. The panel requires 110 VAC input, CANBOA/USA UL listed. The panel has a differential pressure switch and an electrically actuated ball valve that controls the backwash

function.

ACS-2S This system has all of the features of the ACS-1 and includes a motor starter in addition to the other standard equipment.

ACS-3S This system has all of the features of the ACS-2 system and includes a 460V/120V step down transformer.

Optional designs to meet specific requirements with special wiring arrangements, panel boxes (NEMA 7, 9), control valves, and air actuation among others, can be furnished.

MODES OF OPERATION

The automatic intermittent mode is adjustable by setting the timer in the panel that controls the frequency of backwashing and the "open" time of the backwash valve. Field adjustments should be made to suit the application. A differential pressure switch to initiate backwashing under high load conditions also can be adjusted.

The continuous backwashing mode is recommended where the backwashing fluid can be recycled to its source or when very high solid loadings are encountered.

In both the automatic intermittent and continuous backwashing modes the backwash arm continuously rotates at a low 2-4 RPM.



COMPONENTS

Motors An electric motor and gear box are furnished as part of the strainer. The standard TEFC motor is 120V/220V, Single phase 60 Hz, or 230V/460V Three Phase 60 Hz, at customer option. Other motors are available.

Differential Pressure Switch A diaphragm-type differential pressure switch is a standard component in all Control Systems. It compensates for sudden high pressure loading by overriding the time cycle and initiating backwashing. The differential pressure setting as well as a delay time setting can be adjusted. Two psid above the clean reading is the differential setting recommended. A delay timer will continue the cleaning to customer's requirement. The time delay can be adjusted from 0.6 seconds to 24 hours, depending on system's needs.

Backwash Valve Electrically actuated (115 VAC/60 Hz) ball valves are also standard in the Control Systems. Materials of construction are suitable for water service. Other materials, valve types and pneumatic actuation are optional.

Backwash Valve Sizes

Strainer Size	Valve Size
2", 3", 4"	1"
6", 8"	1 1/2"
10", 12", 14", 16"	2"
18", 20", 24", 30"	3"
36"	6"
48", 60"	8"



Powering Business Worldwide

Eaton offers a full range of element choices for Automatic Strainers. All are manufactured to the toughest industry standards and are designed for long term use in even the most demanding applications.



Convoluted Element

This is a sturdy, economical stainless steel element for general service use. It is ideal in applications where leaves, twigs, and large amounts of miscellaneous debris are encountered. The generous spaces created by the convolutions provide an area for the debris to collect. "Packing" does not occur due to the gradual contoured shape of the convolutions. During backwashing the debris is easily dislodged and carried away through the backwash arm and out of the strainer.



DuraWedge® Element

DuraWedge® is a nonclogging, rugged stainless steel straining element constructed from V-shaped profile wire. Available only from Eaton.

FEATURES

- Two point contact straining from the "smooth" side prevents plugging or packing of debris and particles.
- Effective dislodging of dirt, debris, and fibers from the element during backwash. This is accomplished by the increased velocity of the reverse flow (during backwash) from the "open side" of the vee.
- Fiber stapling is reduced because of smooth surfaces and the design contour of the profile wire.
- Vertical collector bars form spaces to accumulate debris and dirt, preventing snow plowing of materials by the rotating backwash arm and port shoe.
- No bypass. Elements are sealed.
- Longer service life. All-welded design with circumferential reinforcing bands provides structural integrity.

DuraWedge Media Selection

Strainer Size	Standard Openings
2", 3", 4", 6", 8"	1/16", 1/32", 0.015"
10", 12", 14", 16"	1/8", 1/16", 1/32", 0.015", 0.009"
18", 20", 24"	3/16", 1/8", 1/16", 1/32", 0.015", 0.009"

FEATURES

- Circumferential reinforcing bands for added resistance to pressure and flexing ensures long service life.
- Cartridge design for easy removal and cleaning.
- Convoluted sections are individually isolated by the port shoe during backwash for increased cleaning efficiency.
- No snow plowing. Convoluted profile provides collection spaces for debris.
- Extended area design offered only by Eaton.
- No bypass.
- Sinter bonded mesh available - An Eaton exclusive.

Convoluted Media Selection

Strainer Size	Standard Openings
Convoluted Perf Element	
2", 3", 4", 6", 8"	1/8", 1/16", 1/32"
10", 12", 14", 16"	1/8", 1/16", 1/32"
18", 20", 24"	5/32", 1/8", 1/16"
Convoluted Mesh Element	
All Sizes	20 mesh (0.015") to 200 mesh (0.003")

North America
44 Apple Street
Tinton Falls, NJ 07724
Toll Free: 800 656-3344
(North America only)
Tel: +1 732 212-4700

China
No. 3, Lane 280,
Linhong Road
Changning District, 200335
Shanghai, P.R. China
Tel: +86 21 5200-0099

Europe/Africa/Middle East
Auf der Heide 2
53947 Nettersheim, Germany
Tel: +49 2486 809-0

Singapore
4 Loyang Lane #04-01/02
Singapore 508914
Tel: +65 6825-1668

Friedensstraße 41
68804 Altlußheim, Germany
Tel: +49 6205 2094-0
An den Nahewiesen 24
55450 Langenlonsheim, Germany
Tel: +49 6704 204-0

Brazil
Rua Clark, 2061 - Macuco
13279-400 - Valinhos, Brazil
Tel: +55 11 3616-8400



Powering Business Worldwide

For more information, please email us at filtration@eaton.com or visit www.eaton.com/filtration

© 2017 Eaton. All rights reserved. All trademarks and registered trademarks are the property of their respective owners. All information and recommendations appearing in this brochure concerning the use of products described herein are based on tests believed to be reliable. However, it is the user's responsibility to determine the suitability for his own use of such products. Since the actual use by others is beyond our control, no guarantee, expressed or implied, is made by Eaton as to the effects of such use or the results to be obtained. Eaton assumes no liability arising out of the use by others of such products. Nor is the information herein to be construed as absolutely complete, since additional information may be necessary or desirable when particular or exceptional conditions or circumstances exist or because of applicable laws or government regulations.

US
4-2017

TECHNICAL DATA

Model 2596 Automatic Self-Cleaning Strainers

Basic Sizing Guidelines

1. Ensure that the pipeline flow velocity falls within the standard design range of the strainer.
2. Select the correct screen and opening size, do not make smaller than necessary.
3. The quantity, type, and nature of debris to be removed are considered.
4. The strainer meets the design pressure and temperature requirements of the pipeline.
5. Backwash line should discharge to atmosphere in close proximity to the strainer.

Standard Design Parameters

1. Self-cleaning strainers have a design flow range where the unit will best perform its two main functions, straining and self-cleaning.
2. Inlet flow velocity to the strainer should be in the 6 to 10 feet per minute range. There may be applications where the operating flow will fall outside the normal design range. When this occurs, please contact Eaton for recommendations.
3. Minimum operating pressure is 20 psi for standard units. Consult Eaton for equipment options when the system pressure is less than 20 psi.
4. Suspended solids should not exceed 200 ppm or 0.02% of volume (see below). For heavier loadings consult Eaton.

STRAINER SIZING CHART

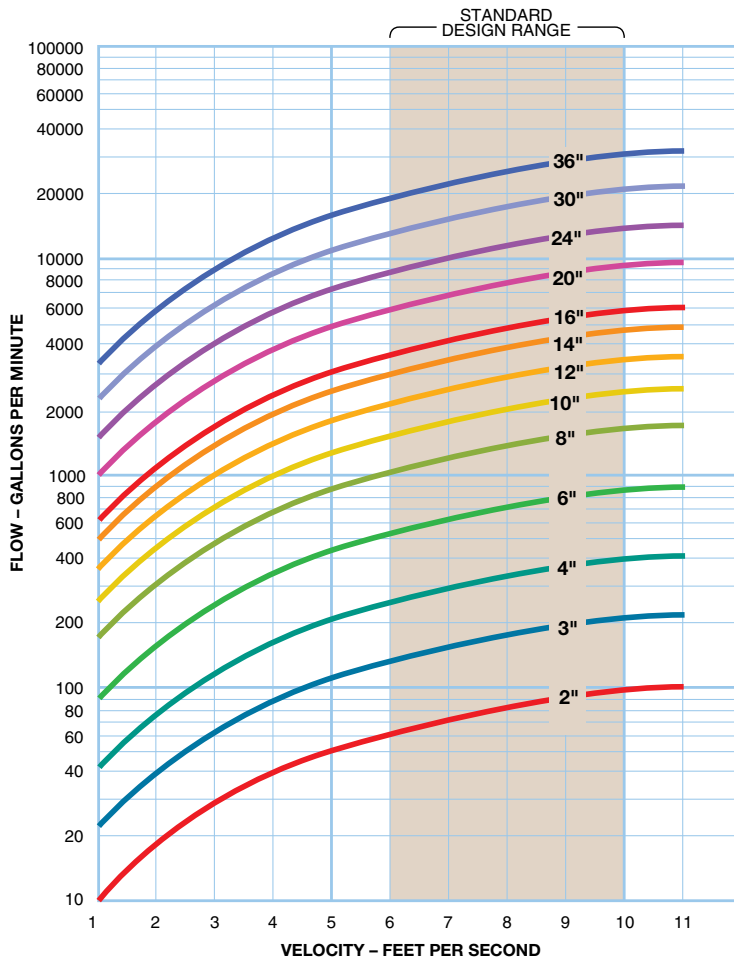

SUSPENDED SOLIDS SIZING CHART AND CONVERSION TABLE

PPM	%	Lbs. / 1000 Gal.
10000	1.0	80
8000	.8	60
6000	.6	40
4000	.4	20
2000	.2	10
1000	.1	8
800	.08	6
600	.06	4
400	.04	2
200	.02	1
100	.01	.8
80	.008	.6
60	.006	.4
40	.004	.2
20	.002	.1
10	.001	.08
8	.0008	.06
6	.0006	.04
4	.0004	.02
2	.0002	.01
1.0	.0001	.0083

A shaded green region covers the bottom half of the table (from 200 PPM down to 1.0 PPM), with a vertical arrow labeled 'STANDARD DESIGN RANGE' pointing upwards.



Powering Business Worldwide

TECHNICAL DATA

Model 2596 Automatic Self-Cleaning Strainers

VOLUME CONVERSION FACTORS

To convert from one unit to another, locate the starting unit in the left column. Multiply by factor horizontally to the right under desired unit.

To Obtain: Multiply By:	U.S. Gallon	Imperial Gallon	U.S. Pint	U.S. Pound Water	U.S. Cubic Foot	U.S. Cubic Inch	Liter	Cubic Meter
U.S. Gallon	1	0.833	8.0	8.337	0.13368	231.0	3.78533	0.003785
Imperial Gallon	1.2009	1	9.60752	10.0	0.16054	277.42	4.54596	0.004546
U.S. Pint	0.125	0.1041	1	1.042	0.01671	28.875	0.473168	0.000473
U.S. Pound Water	0.11995	0.1	0.9596	1	0.016035	27.708	0.45405	0.00454
U.S. Cubic Foot	7.48052	6.22888	59.8442	62.365	1	1728.0	28.31702	0.028317
U.S. Cubic Inch	0.004329	0.00361	0.034632	0.03609	0.0005787	1	0.016387	0.0000164
Liter	0.2641779	0.2199756	2.113423	2.202	0.0353154	61.02509	1	0.001000
Cubic Meter	264.170	219.969	2113.34	2202	35.31446	61023.38	999.972	1

PRESSURE CONVERSION FACTOR

To convert from one unit to another, locate the starting unit in the left column. Multiply by factor horizontally to the right under desired unit.

To Obtain: Multiply By:	Pound Sq. In.	Pound Sq. Ft.	Atmosphere	Kilogram Sq. Cm.	Inch Water	Foot Water	Inch Mercury	mm Mercury	Bar
Pounds/Sq. In	1	144.0	0.068046	0.070307	27.7276	2.3106	2.0360	51.7150	0.06895
Pounds/Sq. Ft.	0.0069545	1	0.000473	0.000488	0.1926	0.01605	0.014139	0.35913	0.000479
Atmosphere	14.696	2116.22	1	1.0332	407.484	33.9570	29.921	760.0	1.01325
Kilogram/Sq. Cm.	14.2233	2048.16	0.96784	1	394.27	32.864	28.959	735.558	0.9807
Inch Water	0.03607	5.194	0.002454	0.00254	1	0.08333	0.0734	1.865	0.00249
Foot Water	0.43278	62.3205	0.029449	0.03043	12.0	1	0.8811	22.381	0.02984
Inch Mercury	0.49115	70.726	0.033421	0.03453	13.617	1.1349	1	25.40	0.03386
mm Mercury	0.019337	2.7845	0.0013158	0.0013595	0.5361	0.04468	0.03937	1	0.001333
Bar	14.5038	2088.55	0.98692	1.0197	33.51	402.1	29.53	750.0	1

STRAINER BASKET OPENING EQUIVALENTS

Mesh	Inches	Millimeters	Microns
200	0.0027	0.0686	68
150	0.0041	0.1041	104
100	0.0065	0.1651	165
80	0.007	0.1778	177
60	0.009	0.2286	228
40	0.015	0.8636	380
20	0.034	0.8636	862

Tighter retentions available, consult Eaton.

STRAINER BASKET OPENING EQUIVALENTS

Perf	Inches	Millimeters	Microns
1/32	0.033	0.838	838
3/64	0.045	1.143	1143
1/16	0.070	1.778	1776
3/32	0.094	2.387	2387
1/8	0.125	3.175	3175
5/32	0.150	3.810	3810
3/16	0.1875	4.762	4762
1/4	0.250	6.350	6350
3/8	0.375	9.525	9525
1/2	0.500	12.700	12700

FLOW VELOCITY CONVERSION FACTORS

$$\text{Velocity in Ft./Sec.} = \frac{\text{GPM} \times 0.4085}{\text{ID}^2 \text{ in Inches}}$$

FLOW CONVERSION FACTORS

M ³ /hr	=	3.671 I.G.M.
I.G.P.M.	=	41.14 Barrels/Day
T.P.H.	=	3.74 I.G.M.
I.G.P.M.	=	1.2 U.S. G.P.M.
I.G.P.M.	=	4.54 Liters/Min
Liter/Min.	=	0.22 I.G.P.M.
U.S. G.P.M.	=	0.833 I.G.P.M.
Barrel	=	35 Imp. Gallons
Barrel	=	42 U.S. Gallons

VISCOSITY EQUIVALENTS

SSU (Saybolt Seconds Universal)	Centipoise	Engler Degrees 20°C	Redwood Standard
30	1	—	—
50	5	2	44
100	20	3.5	88
200	40	16	175
300	65	30	263
400	85	43	350
500	105	57	440
600	130	72	525
700	150	90	615
800	175	115	700
900	195	132	790
1000	210	150	880
2000	425	350	1750
3000	625	540	2600
4000	860	740	3500
5000	1050	930	4550
6000	1300	1120	5250
7000	1500	1320	6150
8000	1700	1510	7300
9000	1920	—	—
10000	2150	—	—

North America
44 Apple Street
Tinton Falls, NJ 07724
Toll Free: 800 656-3344
(North America only)
Tel: +1 732 212-4700

Europe/Africa/Middle East
Auf der Heide 2
53947 Nettersheim, Germany
Tel: +49 6205 2094-0

Friedensstraße 41
68804 Altließheim, Germany
Tel: +49 6205 2094-0

An den Nahewiesen 24
55450 Langenlonsheim, Germany
Tel: +49 6704 204-0

China
No. 3, Lane 280,
Linhong Road
Changning District, 200335
Shanghai, P.R. China
Tel: +86 21 5200-0099

Singapore
4 Loyang Lane #04-01/02
Singapore 508914
Tel: +65 6825-1668

Brazil
Rua Clark, 2061 - Macuco
13279-400 - Valinhos, Brazil
Tel: +55 11 3616-8400

**For more information, please
email us at filtration@eaton.com
or visit www.eaton.com/filtration**

© 2017 Eaton. All rights reserved. All trademarks and registered trademarks are the property of their respective owners. All information and recommendations appearing in this brochure concerning the use of products described herein are based on tests believed to be reliable. However, it is the user's responsibility to determine the suitability for his own use of such products. Since the actual use by others is beyond our control, no guarantee, expressed or implied, is made by Eaton as to the effects of such use or the results to be obtained. Eaton assumes no liability arising out of the use by others of such products. Nor is the information herein to be construed as absolutely complete, since additional information may be necessary or desirable when particular or exceptional conditions or circumstances exist or because of applicable laws or government regulations.

US
4-2017



Powering Business Worldwide

Tubular Backwashing Filter

AFC, AFR & F-Series

Reduce Waste,
Improve Process
Efficiency
& Increase
Product Quality



Industry Leading Family of Solutions

Eaton offers a full line of tubular backwashing solutions to meet your specific application demands and business needs. From the high-capacity AFR-Series for high flow in a compact footprint, to our simple single tube AFC-Series

for stand-alone applications with low solids loading, there is an Eaton solution for any process. All Eaton filters are engineered for the best performance and value in every application.

TUBULAR BACKWASHING FEATURES & BENEFITS

- Tight retentions (as low as 2 micron) with high flow rates—ideal for a wide range of process liquids and parameters
- Eliminates the need for disposable media including bags and cartridges—reduces disposal costs, materials loss, labor, and inventory
- Choice of configurations—available solutions to optimize your system for almost any filtration challenge
- Modular scalable systems—your system can grow with your application demands
- Automated clean-in-place operation—optimizes cleaning frequency and reduces labor demands
- Wide range of operating pressures—capable of reliable operation and performance up to 1,000 psi (69 bar)

Barrier Filtration

Barrier filtration uses either stainless steel or a fabric screen, selected for its retention and flow properties. This filtration media, within the filter housing, collects debris on its surface because the liquid flows inward. Contaminants on the surface slowly form a barrier, capable of removing smaller particles.

Backwash Cleaning

The core principle behind backwashing, when automated, is that the filters are designed to initiate a backwash sequence when the differential pressure reaches its set point. The flow of liquid is reversed, dislodging the debris that has built up on the surface of the filter media. A drain header, located at the base of the filter, provides an outlet for the debris to be purged from the system.



Powering Business Worldwide

TYPICAL APPLICATIONS

- city water lines • hot condensate • chiller water • fresh water
- whitewater / shower water • cip fluids • papermaking wet end starch • pelletizer water • single and duo tubular filters for a wide range of applications up to 1000 psi and high viscosity applications

Tubular Backwashing Filter

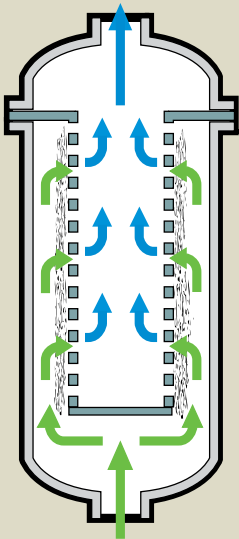

Process liquid flows into the housing inlet at its base and passes across the filter media from the outside inward. Because of this flow path, contaminants collect on the outside of the filter element slowly forming a cake, removing smaller particles.

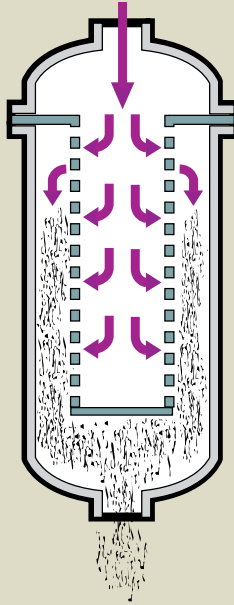

During backwash, triggered by time or pressure differential, a valve switches one station's flow from the inlet header to the drain header and the direction of the flow is reversed in the filter tube, dislodging contaminants from the media surface. The source of the cleaning fluid may be a diversion of process fluids (internal backwashing) or an external source (external backwashing).

Contaminants and the fluids used for cleaning are expelled through the drain header at the base of the unit. Once backwashing is complete, the flow is reversed again and normal filtration resumes.

Cake formation increases filtration efficiency

Whereas the filtration media provides some of the filtration action, collected contaminants further increase efficiency. We call this phenomenon "cake formation." The collected solids, or "cake," trap additional contaminants. The key to making this principle work is timely cleaning—too soon and you lose the benefit, too late and the system flow becomes hindered.

Eaton's filtration systems come factory pre-set to backwash when the differential pressure from inlet to outlet reaches 15 psi (1 bar)—typically the optimum time to initiate backwashing, although this is adjustable.



When your application demands high-pressure operation—up to 1,000 psi (69 bar)—and scalable flexibility, the Eaton AFC-Series is optimal. Systems are available in single, duo, and multiplex configurations to meet your application and business demands.

For liquid filtering applications that require unattended operation, maximum uptime, and solids removal from 2 to 1,700 microns, the Eaton F-Series family of filter systems delivers unbeatable performance.



The revolutionary Eaton AFR-Series delivers high-flow filtration of water-like liquids at retentions as low as 2 micron—in a compact one-square-meter footprint.



North America
44 Apple Street
Tinton Falls, NJ 07724
Toll Free: 800 656-3344
(North America only)
Tel: +1 732 212-4700

China
No. 3, Lane 280,
Linhong Road
Changning District, 200335
Shanghai, P.R. China
Tel: +86 21 5200-0099

Europe/Africa/Middle East
Auf der Heide 2
53947 Nettersheim, Germany
Tel: +49 2486 809-0

Singapore
4 Loyang Lane #04-01/02
Singapore 508914
Tel: +65 6825-1668

Friedensstraße 41
68804 Altlußheim, Germany
Tel: +49 205 2094-0

Brazil
Rua Clark, 2061 - Macuco
13279-400 - Valinhos, Brazil
Tel: +55 11 3616-8400

An den Nahewiesen 24
55450 Langenlonsheim, Germany
Tel: +49 6704 204-0

For more information, please email us at filtration@eaton.com or visit www.eaton.com/filtration

US
4-2017

© 2017 Eaton. All rights reserved. All trademarks and registered trademarks are the property of their respective owners. All information and recommendations appearing in this brochure concerning the use of products described herein are based on tests believed to be reliable. However, it is the user's responsibility to determine the suitability for his own use of such products. Since the actual use by others is beyond our control, no guarantee, expressed or implied, is made by Eaton as to the effects of such use or the results to be obtained. Eaton assumes no liability arising out of the use by others of such products. Nor is the information herein to be construed as absolutely complete, since additional information may be necessary or desirable when particular or exceptional conditions or circumstances exist or because of applicable laws or government regulations.

Tubular Backwashing Filter

AFC-Series

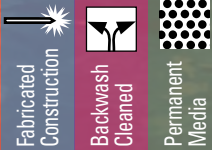

When an application demands high-pressure operation – up to 1,000 psi (69 bar) – and scalable flexibility, the Eaton AFC-Series is optimal. Systems are available in single, duo, and multiplex configurations.

FEATURES/BENEFITS

- Solids removal from 2 to 1,700 microns
- Single system flow rates up to 3,000 gpm (681 m³/hr)
- Broad selection of filter media materials and retentions suitable for a wide range of applications
- Smooth pipe and nozzle connection transitions to avoid dead spots in the fluid stream and minimize pressure drop
- Numerous automated backwash options for operator-free service and minimal backwash effluent (<2% of system volume)
- Available ACCUFLUX™ media dramatically increases filter surface area in the same footprint
- Proprietary 3-way, full-ported valves on AFC-1100 multiplex filters allow fast, frequent sequencing and maximum cleaning force during backwashing
- Isolated top-to-bottom backwash flow on AFC-1100, 2200 and AFC-3300 multiplex filters ensures complete and efficient media cleaning while continuing to deliver filtered product downstream
- Quick coupler valve connectors for ease of body tube removal

OPTIONS

- Straight-thru and Standard configurations
- Single, duo and multiplex (up to 20 station) models
- Pressure gauge and drain valve options
- Internal or external backwashing
- Drain header trap
- Media-cleaning diffusers for more effective cleaning at low operating pressures or volumes
- 304 stainless steel frame material



Powering Business Worldwide

Straight-Thru Design

Single Filters

Designed for batch or intermittent service, AFC-Series filters are ideal for a wide range of applications. Quick coupling connectors afford easy media access for inspection, cleaning, or replacement. Choice of straight-thru and standard configurations, both are available with pressure gauge and drain valve options.

Duo Filters

Two single filter units are connected to a pair of 3-way valves for continuous service during cleaning or maintenance. If a pressure rating above 350 psi is required, 2-way ball valves rated at 1,000 psi are incorporated. For intermittent service applications, the valves can be positioned so that both units operate simultaneously.

Multiplex Filters

Multiplex units consist of two or more single filter units valved in parallel to common headers. This configuration enables sequential backwashing of individual elements while the system remains in operation.



AFC-2200 Multiplex High-Pressure Unit

TYPICAL APPLICATIONS

- city water lines • hot condensate • chiller water • fresh water
- whitewater / shower water • cip fluids • papermaking wet end starch
- pelletizer water • single and duo tubular filters for a wide range of applications up to 1000 psi and high viscosity applications

Single and Duo

	1100	1500	2200	3300 ¹				
Body Inlet/Outlet Size - in (mm)	1 (25.4)	1.5 (38.1)	2 (50.8)	3 (76.2)				
Body Diameter - in (mm)	2.875 (73)	3.5 (88.9)	4.5 (114.3)	4.5 (114.3)				
Screen Length - in (mm)	12 (304.8) 18 (457.2)	24 (381) 36 (914.4)	18 (457.2) 36 (914.4)	18 (457.2) 36 (914.4)				
Element Styles Available ² - in (mm)	2 (50.8) dia. single	2.25 (57.1) dia. single	3.25 (82.8) dia. single, Tri-Cluster, Accuflux - 7	3.25 (82.8) dia. single, Tri-Cluster, Accuflux - 7				
Pressure Rating ³ - psi (bar)	150 (10.3) 250 (17.2) ⁴	150 (10.3) 250 (17.2) ⁴	150 (10.3) 250 (17.2) ⁴ 350 (24.1), 740 (51.7), +1000 (101.3) ^{4/5}	150 (10.3)				
Total Volumetric Capacity - Model #'s	1112	1118	1524	1536	2218	2236	3318	3336
Single Unit - gal (l)	0.4 (1.5)	0.5 (1.9)	1 (3.8)	1.4 (5.3)	1.3 (4.9)	2.4 (9.1)	1.3 (4.9)	2.4 (9.1)
Duo-Unit - gal (l)	0.8 (3.0)	1 (3.8)	2 (7.6)	2.8 (10.6)	2.6 (9.8)	4.8 (18.2)	2.6 (9.8)	4.8 (18.2)
Single Unit Weight - lbs (kg)	15 (6.8)	18 (8.2)	25 (11.3)	30 (13.6)	35 (15.9)	40 (18.1)	40 (18.1)	45 (20.4)
Duo Unit Weight - lbs (kg)	80 (36.3)	90 (40.8)	110 (49.9)	125 (56.7)	140 (63.5)	160 (72.6)	180 (81.6)	300 (136.0)
Drain Size ⁶ - in (mm)	Standard 0.75 (19)	Straight-Thru 0.5 (12.7)	Standard 0.75 (19)	Straight-Thru 0.5 (12.7)	Standard 1.25 (31.75)	Straight-Thru 0.5 (12.7)	Straight-Thru 0.5 (12.7)	

¹Available in Straight-Thru design only ²Consult media availability chart for specific retentions and types available. ³Teflon gaskets limit pressure maximum to 80 psi (5.5 bar)

⁴All high pressure units (250 psi and over) incorporate 2-way ball valves. ⁵Duo configuration 350, 740 and 1000 psi available in Straight-Thru design only. ⁶Consult factory for optional additional drain sizes

Multiplex

	1100	2200	3300
Body Inlet/Outlet Size - in (mm)	1 (25.4)	2 (50.8)	3 (76.2)
Inlet/Outlet Header Size ¹ - in (mm)	3 (76.2) 4 (101.8)	3 (76.2) 4 (101.8) 6 (152.4) 8 (203.2) 10 (254.0) 12 (304.8)	3 (76.2) 4 (101.8) 6 (152.4) 8 (203.2) 10 (254.0) 12 (304.8)
Body Diameter - in (mm)	2.875 (73)	4.25 (114.3)	4.25 (114.3)
Screen Length - in (mm)	18 (457.2)	36 (914.4)	36 (914.4)
Element Styles Available ² - in (mm)	2 (50.8) diameter single	3.25 (82.3) diameter single, Tri-Cluster, Accuflux - 7	3.25 (82.3) diameter single, Tri-Cluster, Accuflux - 7
Pressure Rating ³ - psi (bar)	150 (10.3) 250 (17.2)	1000 (101.3)	150 psi (10.3 bar)
Air Requirement (Automated Units)	60-120 psi (4.1-8.3 bar) @ 5 cfm, for sequencing	60-120 psi (4.1-8.3 bar) @ 5 cfm, for sequencing	60-120 psi (4.1-8.3 bar) @ 5 cfm, for sequencing
Electrical Requirement (Automated Units)	110/220 V, 50/60 Hz, single phase	110/220 V, 50/60 Hz, single phase	110/220 V, 50/60 Hz, single phase

¹Drain header size 3" (76.2). Consult factory for custom sizes ²Consult media availability chart for specific retentions and types available.

³Teflon gaskets limit pressure maximum to 80 psi (5.5 bar) AFC 2200 available in 1000 psi (101.3 bar) only



AFC-1100 Multiplex Unit

North America
44 Apple Street
Tinton Falls, NJ 07724
Toll Free: 800 656-3344
(North America only)
Tel: +1 732 212-4700

Europe/Africa/Middle East
Auf der Heide 2
53947 Nettersheim, Germany
Tel: +49 2486 809-0

Friedensstraße 41
68804 Altlußheim, Germany
Tel: +49 6205 2094-0

An den Nahewiesen 24
55450 Langenlonsheim, Germany
Tel: +49 6704 204-0

China
No. 3, Lane 280,
Linhong Road
Changning District, 200335
Shanghai, P.R. China
Tel: +86 21 5200-0099

Singapore
4 Loyang Lane #04-01/02
Singapore 508914
Tel: +65 6825-1668

Brazil
Rua Clark, 2061 - Macuco
13279-400 - Valinhos, Brazil
Tel: +55 11 3616-8400

**For more information, please
email us at filtration@eaton.com
or visit www.eaton.com/filtration**

© 2017 Eaton. All rights reserved. All trademarks and registered trademarks are the property of their respective owners. All information and recommendations appearing in this brochure concerning the use of products described herein are based on tests believed to be reliable. However, it is the user's responsibility to determine the suitability for his own use of such products. Since the actual use by others is beyond our control, no guarantee, expressed or implied, is made by Eaton as to the effects of such use or the results to be obtained. Eaton assumes no liability arising out of the use by others of such products. Nor is the information herein to be construed as absolutely complete, since additional information may be necessary or desirable when particular or exceptional conditions or circumstances exist or because of applicable laws or government regulations.

US
4-2017



Powering Business Worldwide

Tubular Backwashing Filter

F-Series

Fabricated
Construction

Backwash
Cleaned

Permanent
Media

For liquid filtering that requires unattended operation, maximum uptime, and solids removal from 2 to 1,700 microns, the Eaton F-Series delivers unbeatable performance.



FEATURES/BENEFITS

- Solids removal from 2 to 1,700 microns
- Single system flow rates up to 3,000 gpm (681 m³/hr)
- Smooth pipe and nozzle connection transitions to avoid dead spots in the fluid stream and minimize pressure drop
- Broad selection of filter media materials and retentions suitable for a wide range of applications
- Proprietary 3-way, full-ported valves allow fast, frequent sequencing and maximum cleaning force during backwashing
- Isolated top-to-bottom backwash flow ensures complete and efficient media cleaning while continuing to deliver filtered product downstream
- Numerous automated backwash options for operator-free service and minimal backwash effluent (<2% of system volume)
- Available ACCUFLUX™ media dramatically increases filter surface area in the same footprint

OPTIONS

- Internal or external backwashing
- Media-cleaning diffusers for more effective cleaning at low operating pressures or volumes
- Drain header trap
- Quick coupler valve connectors for ease of body tube removal
- 304 stainless steel frame material
- ASME code vessels

TYPICAL APPLICATIONS

- city water lines • hot condensate • chiller water • fresh water
- whitewater / shower water • cip fluids • papermaking wet end starch • pelletizer water • single and duo tubular filters for a wide range of applications up to 1000 psi and high viscosity applications

The key to the F-Series' versatility is its modular design that enables future capacity and configuration flexibility. F-Series systems can include 2 to 24 body tubes on a single framed skid and can be ordered with blank stations to allow low-cost expanded capacity.

The F-Series uses cleanable media. This further reduces life cycle costs and maximizes productivity by eliminating the labor, replacement, and disposal costs of bags and cartridges. Three types of elements are offered: single element with 364 in² of surface area, the Tri-Cluster® with 510 in² of surface area, or the Accuflux® 7 with 791 in² of surface area.

The F-Series features 3-way ball valves, automated cleaning with direct mounted actuators and solenoids, and available blank stations for easy future expansion.

How the F-Series Works

When cleaning is required, triggered by time or pressure differential, a single valve removes the tube to be backwashed from the incoming flow stream. The resulting pressure drop redirects a portion of the clean process flow downward, flushing the contaminants to the drain manifold. When process liquids are very valuable or hazardous, an external backwash configuration, which uses a small amount of cleaning liquid introduced through a separate manifold, is recommended. External backwashing is also recommended when operating pressures are expected to be less than 45 psi (3.1 bar).

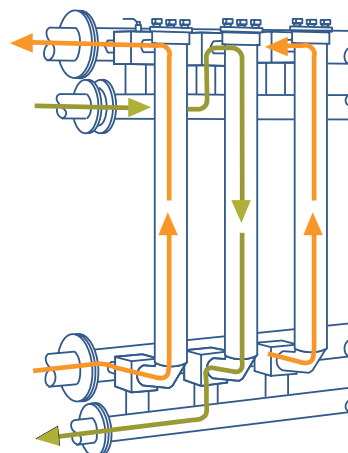

External backwash system shown. Secondary header at the top of the unit introduces cleaning fluid, typically water, (green arrows) to loosen and discharge debris to the drain header at the bottom.

EATON

Powering Business Worldwide

F-Series Tubular Backwashing Filter

SPECIFICATIONS

Body Inlet/Outlet Size - in (mm)	3 (76.2)
Inlet/Outlet Header Size ¹ - in (mm)	3 (76.2), 4 (101.8), 8 (203.2), 10 (254), 12 (304.8)
Body Diameter - in (mm)	4.5 (114.3)
Screen Length - in (mm)	36 (914.4)
Element Styles Available ²	3.25 (82.8) dia. single, Tri-Cluster, Accuflux-7
Pressure Rating ³ - psi (bar)	250 (17.2)
Temperature - °F (°C)	350 (177) system maximum (determined by screen material and elastomer seals)
Air Requirement-auto units - psi (bar)	60 - 120 (4.1-8.3) @ 5 cfm, for sequencing
Electrical Requirement -	110/220V, 50/60 Hz, single phase
Backwash minimum flow	90 gpm (340 l/min) for single and Tri-Cluster media; 150 gpm (567 l/min) for ACCUFLUX™ media

¹Drain header size 3" (76.2). Consult factory for custom sizes

²Consult media availability chart for specific retentions and types available

³Teflon gaskets limit pressure maximum to 80 psi (5.5 bar). ASME code units are limited to 150 psi (10.3 bar)

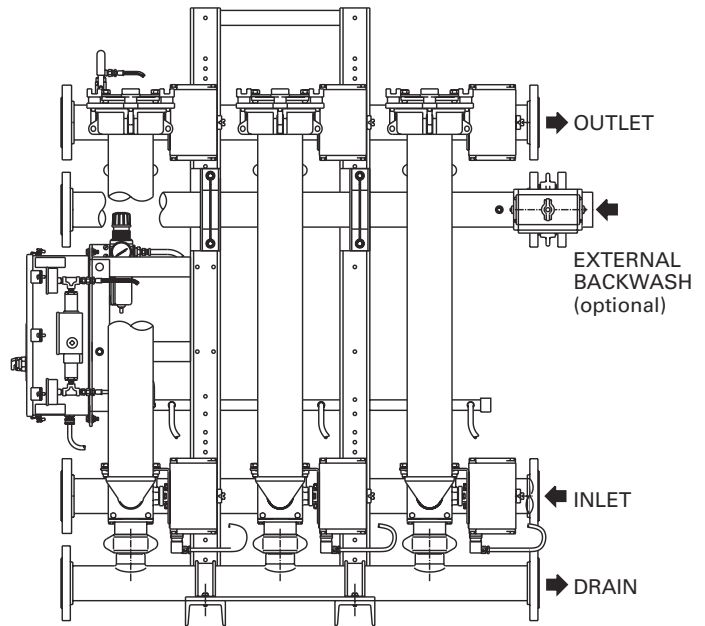

3-way ball valves

To ensure positive sealing and maximum flow, our F-Series filters feature the industry's best 3-way ball valves. These important components—designed and manufactured by Eaton exclusively for Eaton systems—were developed specifically for the demands of industrial filtration. Their full-ported design reduces pressure drop and requires no additional linkages for actuation.

Model	Weight (dry) lbs (kg)	Height in (mm)	Footprint w x l in (mm)	Volume gal (l)	Configuration # of Tubes
F202	450 (204)	62 (1575)	28.5 x 45 (725 x 1145)	18 (68)	2
F203	600 (272)	62 (1575)	28.5 x 48 (725 x 1220)	23 (87)	3
F204	750 (340)	62 (1575)	28.5 x 63 (725 x 1600)	30 (114)	4
F205	900 (408)	62 (1575)	28.5 x 78 (725 x 1980)	37 (140)	5
F206	1200 (544)	62 (1575)	28.5 x 93 (725 x 2360)	65 (246)	6
F207	1350 (612)	62 (1575)	28.5 x 108 (725 x 2745)	75 (284)	7
F208	1500 (680)	62 (1575)	28.5 x 123 (725 x 3125)	85 (322)	8
F209	1800 (816)	62 (1575)	28.5 x 138 (725 x 3505)	124 (470)	9
F210	1950 (885)	62 (1575)	28.5 x 153 (725 x 3885)	138 (522)	10
F211	2100 (952)	62 (1575)	28.5 x 168 (725 x 4265)	151 (572)	11
F212	2400 (1089)	62 (1575)	28.5 x 183 (725 x 4650)	165 (625)	12

North America
44 Apple Street
Tinton Falls, NJ 07724
Toll Free: 800 656-3344
(North America only)
Tel: +1 732 212-4700

Europe/Africa/Middle East
Auf der Heide 2
53947 Nettersheim, Germany
Tel: +49 2486 809-0

Friedensstraße 41
68804 Altlußheim, Germany
Tel: +49 6205 2094-0

An den Nahewiesen 24
55450 Langenlonsheim, Germany
Tel: +49 6704 204-0

China
No. 3, Lane 280,
Linhong Road
Changning District, 200335
Shanghai, P.R. China
Tel: +86 21 5200-0099

Singapore
4 Loyang Lane #04-01/02
Singapore 508914
Tel: +65 6825-1668

Brazil
Rua Clark, 2061 - Macuco
13279-400 - Valinhos, Brazil
Tel: +55 11 3616-8400

**For more information, please
email us at filtration@eaton.com
or visit www.eaton.com/filtration**

US
4-2017

© 2017 Eaton. All rights reserved. All trademarks and registered trademarks are the property of their respective owners. All information and recommendations appearing in this brochure concerning the use of products described herein are based on tests believed to be reliable. However, it is the user's responsibility to determine the suitability for his own use of such products. Since the actual use by others is beyond our control, no guarantee, expressed or implied, is made by Eaton as to the effects of such use or the results to be obtained. Eaton assumes no liability arising out of the use by others of such products. Nor is the information herein to be construed as absolutely complete, since additional information may be necessary or desirable when particular or exceptional conditions or circumstances exist or because of applicable laws or government regulations.



Powering Business Worldwide

Tubular Backwashing Filter

AFR-Series

Fabricated
Construction

Backwash
Cleaned

Permanent
Media

The revolutionary Eaton AFR-Series delivers high-flow filtration of water-like liquids at retentions as low as 2 microns in a compact one-square-meter footprint.

FEATURES/BENEFITS

- Solids removal from 2 to 1,700 microns
- Flow rates up to 2,000 gpm (454 m³/hr)
- Broad selection of filter media materials and retentions suitable for a wide range of applications
- Numerous automated backwash options for operator-free service and minimal backwash effluent (<2% of system volume)
- Smooth pipe and nozzle connection transitions to avoid dead spots in the fluid stream and minimize pressure drop
- Isolated top-to-bottom backwash flow for complete and efficient media cleaning while continuing to deliver filtered product downstream
- Available ACCUFLUX™ media dramatically increases filter surface area in the same footprint
- Configured with an array of up to eight - 4" (101.8 mm) or 6" (152.4 mm) body tubes surrounding a central cleaning valve

OPTIONS

- Media-cleaning diffusers for more effective cleaning with low operating pressures or volumes
- Drain header trap
- Isolation butterfly valves for individual body tube removal while filter is in operation
- Hinge-lock quick couplings
- 304 stainless steel frame material

TYPICAL APPLICATIONS

- city water lines • hot condensate • chiller water • fresh water
- whitewater / shower water • cip fluids • papermaking wet end starch • pelletizer water • single and duo tubular filters for a wide range of applications up to 1000 psi and high viscosity applications



How the AFR-Series Works

A single AFR-Series equals the performance of an in-line filter in only one-fifth the floor space. AFR-Series minimizes the number of moving parts for low-cost operation and long service life. A single rotating flow diverter replaces multiple valves, actuators, linkages, and seals required by other systems.

Like many Eaton filters, the AFR-Series uses cleanable media. This core design philosophy further reduces life cycle costs and maximizes productivity by eliminating labor and disposal costs as well as lost production associated with bags and cartridges.

The AFR-Series uses a circular configuration of up to eight tubular filter housings. Process fluid flows into the housing at the inlet at its base and passes across the filter media from the outside inward. Due to this flow path, contaminants collect on the outside of the filter element slowly forming a cake, removing smaller particles.

During backwash, triggered by time or pressure differential, the flow diverter inside the cleaning valve rotates to the tube to be cleaned. This closes

the tube to the incoming process liquid and opens it to the atmosphere (via a drain line). The result causes outlet process liquid to flow in reverse through the element, cleaning it of contaminants and expelling them through the drain at the top of the system.

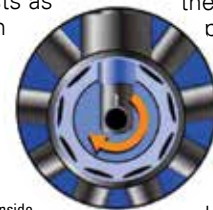

Flow diverter inside the AFR's cleaning valve

EATON

Powering Business Worldwide

AFR Tubular Backwashing Filter

SPECIFICATIONS

Connection Inlet and Outlet: 8" ANSI or 200 mm DIN flanged.
 Drain: 3" (80 mm) weld stub

Process Parameters Temperature: 300°F (149°C) maximum
 (determined by screen material and elastomer seals).
 Operating pressure: up to 250 psi (17 bar)

Elastomer Seals Standard: Buna-N (180°F (82°C) max).
 Optional: Nordel (230°F (110°C) max); Viton® (350°F (149°C) max)

Housing/ Wetted Parts Materials Standard: 316 stainless steel.
 Optional: Wide range available; consult Eaton

Frame Material Standard: Painted carbon steel.
 Optional: 304 stainless steel

Automation Standard: Choice of programmable logic controller
 (PLC) or semi-automatic. Optional: Wide range available; ask
 your representative for more information

Utilities Electrical: 110 or 220 Volt, 50 or 60 Hz, single-phase.
 Air: 60-120 psi (4.1-8.3 bar) @ 5 cfm. Air must be clean, dry
 and non-lubricated

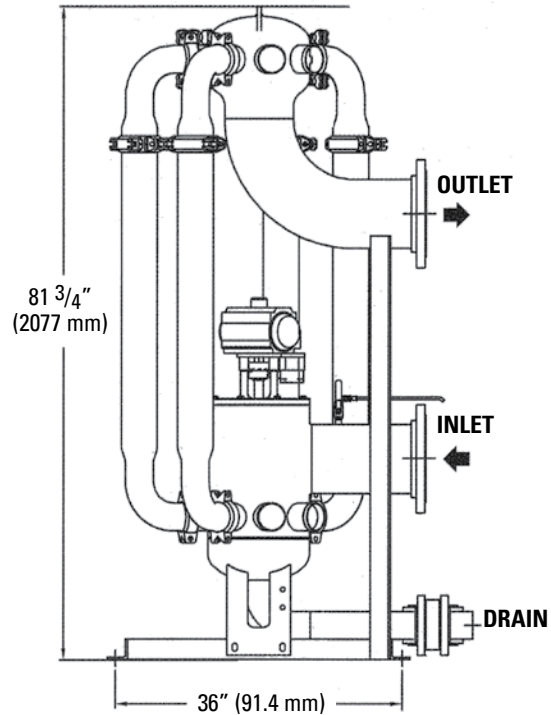

	AFR-8-4	AFR-8-6
Body Inlet/Outlet Size - in. (mm)	3 (76.2)	3 (76.2)
Inlet Outlet Header Size ¹ - in. (mm)	8 (203.2)	8 (203.2)
Body Diameter - in. (mm)	4 (101.8)	6 (152.4)
Screen Length - in. (mm)	36 (914.4)	36 (914.4)
Element Styles Available ² - in. (mm)	3.25 (82.8) diameter single, Tri-Cluster, Accuflux-7	5-Cluster, 7-Cluster, Accuflux-15
Pressure Rating - psi (bar)	250 (17.2)	250 (17.2)
Volumetric Capacity	Each body tube = 4 gallons	Each body tube = 4.8 gallons
Single Unit Weight ³ - lbs. (kg)	1,100 (499)	1,300 (590)
Air Requirement	60-120 psi (4.1-8.3 bar) @ 5 cfm for sequencing	60-120 psi (4.1-8.3 bar) @ 5 cfm, for sequencing
Electrical Requirement	110/220 V, 50/60 Hz, single phase	110/220 V, 50/60 Hz, single phase

¹Drain connection is 3" (76.2) weld stub ²Consult media availability chart for specific retentions and types available

³Weights are approximate and assume eight filled stations

North America
 44 Apple Street
 Tinton Falls, NJ 07724
 Toll Free: 800 656-3344
 (North America only)
 Tel: +1 732 212-4700

China
 No. 3, Lane 280,
 Linhong Road
 Changning District, 200335
 Shanghai, P.R. China
 Tel: +86 21 5200-0099

Europe/Africa/Middle East
 Auf der Heide 2
 53947 Nettersheim, Germany
 Tel: +49 2486 809-0

Singapore
 4 Loyang Lane #04-01/02
 Singapore 508914
 Tel: +65 6825-1668

Friedensstraße 41
 68804 Altlußheim, Germany
 Tel: +49 6205 2094-0

Brazil
 Rua Clark, 2061 - Macuco
 13279-400 - Valinhos, Brazil
 Tel: +55 11 3616-8400

An den Nahewiesen 24
 55450 Langenlonsheim, Germany
 Tel: +49 6704 204-0



Powering Business Worldwide

**For more information, please
 email us at filtration@eaton.com
 or visit www.eaton.com/filtration**

US
 4-2017

© 2017 Eaton. All rights reserved. All trademarks and registered trademarks are the property of their respective owners. All information and recommendations appearing in this brochure concerning the use of products described herein are based on tests believed to be reliable. However, it is the user's responsibility to determine the suitability for his own use of such products. Since the actual use by others is beyond our control, no guarantee, expressed or implied, is made by Eaton as to the effects of such use or the results to be obtained. Eaton assumes no liability arising out of the use by others of such products. Nor is the information herein to be construed as absolutely complete, since additional information may be necessary or desirable when particular or exceptional conditions or circumstances exist or because of applicable laws or government regulations.

Cleanable Media

Matching media configuration, retention, and materials to your application is easy when selecting an Eaton tubular backwashing filtration system. Eaton offers media choices from compact configurations—that pack a large amount of surface area into a small amount of space—to simple strainer-type systems for removing larger contaminants.

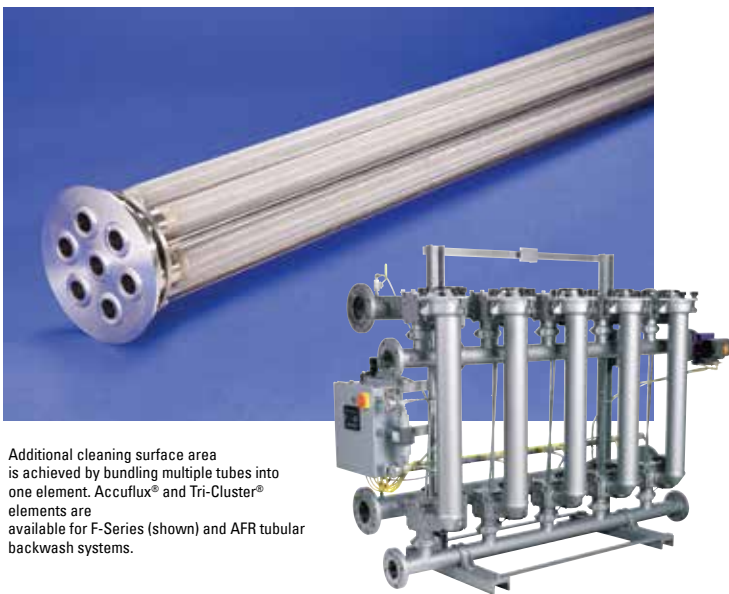

Additional cleaning surface area is achieved by bundling multiple tubes into one element. Accuflux® and Tri-Cluster® elements are available for F-Series (shown) and AFR tubular backwash systems.

TUBULAR BACKWASHING MEDIA MATERIAL

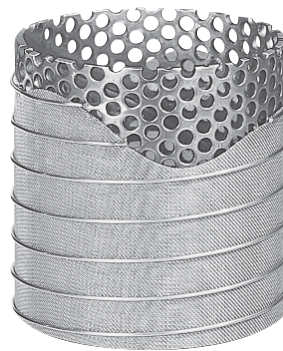

Wire mesh: 1,650 – 2 microns

Woven screens made of 316 stainless steel with a 316 stainless steel backing for added strength. Provide maximum open area (for high flows), excellent contaminant release properties, and a long operating life.



Fabric: 230 – 2 microns

For the finest filtration applications, fabric media deliver reliable contaminant removal down to 1 micron. Fabric screens are supported by a 316 stainless steel backing and are chemically compatible with most process liquids.



Slotted: 1,600 – 25 microns

Made by winding a continuous triangular-shaped wire around a series of vertical support stringers, these media require no backing. Their inherent strength makes them ideal for reliable performance with abrasive slurries or fibrous materials.



Powering Business Worldwide

Tubular Backwashing Filter Media

Media	Particle Retention			Type						Percentage of Open Area	
	Mesh	Inches	Micron	Single	Tri-Cluster	Five-Cluster	Seven-Cluster	Accuflux 7	Accuflux 15		
WIRE MESH	10	0.065	1650	x	x	x				56%	
	20	0.035	890	x	x	x				46%	
	30	0.023	585	x	x	x	x		x	41%	
	40	0.015	380	x	x	x	x		x	36%	
	60	0.009	230	x	x	x	x		x	27%	
	80	0.007	180	x	x	x	x			32%	
	100	0.0055	140	x	x	x	x		x	30%	
	150	0.0046	115	x	x	x	x			37%	
	200	0.0033	84	x	x	x				33%	
	250	0.0024	60	x	x	x		x	x	36%	
	400	0.0018	45	x	x	x		x	x	36%	
	700	0.0012	30	x	x	x		x	x	25%	
	-	-	20						x	x	-
	-	-	10						x	x	-
-	-	5						x	x	-	
-	-	2						x	x	-	
SLOTTED WEDGE WIRE	10	0.063	1600	x	x	x				50%	
	15	0.045	1140	x	x	x				43%	
	20	0.035	890	x	x	x				36%	
	30	0.024	610	x	x	x	x	x		30%	
	40	0.015	380	x	x	x	x	x		20%	
	60	0.009	230	x	x	x	x	x		18%	
	80	0.007	180	x	x	x				15%	
	100	0.006	150	x	x	x	x	x		13%	
	120	0.005	125	x	x	x				11%	
	150	0.004	100	x	x	x				9%	
	200	0.003	75	x	x	x				7%	
	325	0.002	50	x	x	x				5%	
	-	0.001	25	x	x	x	x	x	x		3.2%
	FABRIC MESH	60	0.009	230	x	x	x				Percentage of open area not applicable to fabric media.
80		0.007	180	x	x	x					
100		0.0055	140	x	x	x					
150		0.0046	115	x	x	x					
250		0.0024	60	x	x	x					
500		0.0016	40	x	x						
-		-	25-30	x	x	x					
-		-	15-20	x	x	x					
-		-	5-10	x	x	x					
-	-	1-3	x	x	x						



- **ACCUFLUX®** - The most efficient way to achieve a low flux rate is to increase active filter surface area. This has been achieved with Eaton's AccuFlux media elements featuring ultra-high surface area, clustered element designs, and new-age media materials. AccuFlux elements are available in configurations with 7 or 15 individual, replaceable filter tubes
- **TRI-CLUSTER®** - Three-tube 1 1/2" diameter media for 40% greater surface area than single element designs, with an economical initial investment
- **Additional Media Options** - Select from single tube to five-cluster or seven-cluster designs to meet your specific demands. All are available in wire mesh, fabric, and slotted wedge wire designs

North America
44 Apple Street
Tinton Falls, NJ 07724
Toll Free: 800 656-3344
(North America only)
Tel: +1 732 212-4700

China
No. 3, Lane 280,
Linhong Road
Changning District, 200335
Shanghai, P.R. China
Tel: +86 21 5200-0099

Europe/Africa/Middle East
Auf der Heide 2
53947 Nettersheim, Germany
Tel: +49 2486 809-0

Singapore
4 Loyang Lane #04-01/02
Singapore 508914
Tel: +65 6825-1668

Friedensstraße 41
68804 Altlußheim, Germany
Tel: +49 6205 2094-0

Brazil
Rua Clark, 2061 - Macuco
13279-400 - Valinhos, Brazil
Tel: +55 11 3616-8400

An den Nahewiesen 24
55450 Langenlonsheim, Germany
Tel: +49 6704 204-0



Powering Business Worldwide

For more information, please email us at filtration@eaton.com or visit www.eaton.com/filtration

© 2017 Eaton. All rights reserved. All trademarks and registered trademarks are the property of their respective owners. All information and recommendations appearing in this brochure concerning the use of products described herein are based on tests believed to be reliable. However, it is the user's responsibility to determine the suitability for his own use of such products. Since the actual use by others is beyond our control, no guarantee, expressed or implied, is made by Eaton as to the effects of such use or the results to be obtained. Eaton assumes no liability arising out of the use by others of such products. Nor is the information herein to be construed as absolutely complete, since additional information may be necessary or desirable when particular or exceptional conditions or circumstances exist or because of applicable laws or government regulations.

US
4-2017

Tubular Backwashing Filter

Components & Options

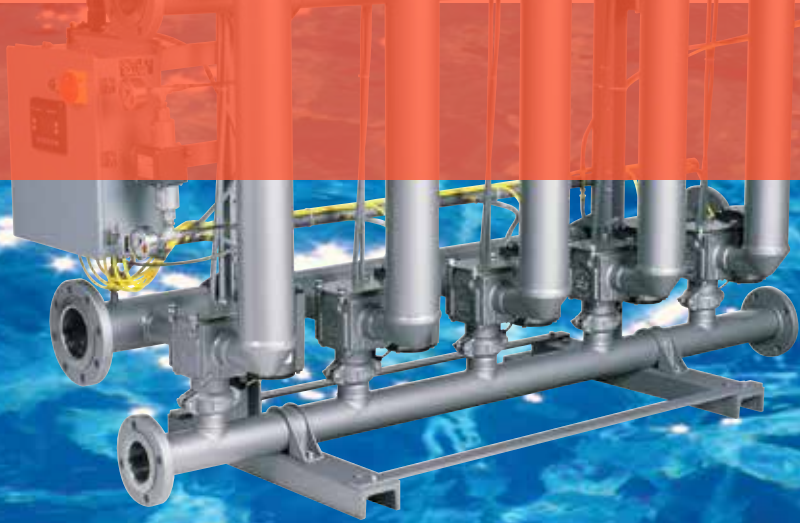

Eaton offers tubular backwashing systems with a full spectrum of standard and optional features. You can customize a system to precisely fit the demands of your application and process. Our experienced team can help seamlessly integrate a filtration solution into your new or existing application for optimum performance.



3-way ball valves

To ensure positive sealing and maximum flow, Eaton's F-Series filters and AFC Multiplex Filters feature the industry's best 3-way ball valves. These important components—designed and manufactured exclusively for Eaton systems—were developed specifically for the demands of industrial filtration. The full-ported design reduces pressure drop and requires no additional linkages for actuation.

TUBULAR BACKWASHING CONTROL OPTIONS



Eaton HMi Operator Interface

HMi is the workhorse of the industry. Ideal for machinery OEMs, the HMi series provides the most value with the latest technology and advanced feature set in an economical hardware and software package.

Features include:

- Screen and backlight saver
- Animated graphics
- Ethernet, COMM port and USB upload/download
- USB ports for data storage
- Three serial ports
- Alarm/event recording and viewing
- Real-time and historical trending

Semi-Automatic

The semi-automatic design includes rotary actuators, solenoid valves, differential pressure switch, and a terminal strip for wiring to the customer's control system. The enclosure is polyester coated carbon steel and is mounted to the filter frame. Includes mode lights and selector switch (run/stop/backwash).



Powering Business Worldwide

WIDE RANGE OF AVAILABLE OPTIONS

Eaton tubular backwashing systems can be ordered with a wealth of custom options to precisely match your application and business demands. Examples include:

- ASME code vessels (F-Series housings only)
- Quick couplers on inlet and outlet of body tubes on F-Series housings for easy removal
- Back-to-back station configuration to reduce footprint (available on multiplex units with four or more stations)
- 304 stainless steel frame material
- Butterfly isolation valves on each station (AFR-Series only)
- Electropolished interiors available upon request

System and media sealing

A filtration system that leaks or allows process fluid bypass is not effective.

Eaton sealing systems are designed to ensure that even with minimal training, your operators can easily obtain a perfect seal. We also offer a wide range of elastomer materials to meet the temperature, pressure, and chemical properties of your process stream.



A total process perspective

When you choose Eaton as your filtration partner for a tubular backwashing system, you are choosing an expert. Not just in the science of filtration, but in how it can benefit your manufacturing process and even help you meet specific production objectives. We consider not just the filter, but how it integrates into your entire process. We can show you the impact that a change in filtration can offer your business.



Differential pressure system for optimum cleaning timing

Automated systems are designed to initiate a backwash sequence when the differential pressure reaches its set point. A timer switch is also used as a backup.



Drain header trap for efficient backwashing

The addition of a simple, optional drain header trap prevents the drain header from drying out and helps minimize water-hammering during the cleaning cycle.

Diffusers optimize cleaning

For challenging solids removal, Eaton offers two styles of backwash diffusers to effectively distribute backwash flow and ensure removal of all contaminants from the filtration media.



North America
44 Apple Street
Tinton Falls, NJ 07724
Toll Free: 800 656-3344
(North America only)
Tel: +1 732 212-4700

China
No. 3, Lane 280,
Linhong Road
Changning District, 200335
Shanghai, P.R. China
Tel: +86 21 5200-0099

Europe/Africa/Middle East
Auf der Heide 2
53947 Nettersheim, Germany
Tel: +49 2486 809-0

Singapore
4 Loyang Lane #04-01/02
Singapore 508914
Tel: +65 6825-1668

Friedensstraße 41
68804 Altlußheim, Germany
Tel: +49 6205 2094-0

Brazil
Rua Clark, 2061 - Macuco
13279-400 - Valinhos, Brazil
Tel: +55 11 3616-8400

An den Nahewiesen 24
55450 Langenlonsheim, Germany
Tel: +49 6704 204-0



Powering Business Worldwide

For more information, please email us at filtration@eaton.com or visit www.eaton.com/filtration

© 2017 Eaton. All rights reserved. All trademarks and registered trademarks are the property of their respective owners. All information and recommendations appearing in this brochure concerning the use of products described herein are based on tests believed to be reliable. However, it is the user's responsibility to determine the suitability for his own use of such products. Since the actual use by others is beyond our control, no guarantee, expressed or implied, is made by Eaton as to the effects of such use or the results to be obtained. Eaton assumes no liability arising out of the use by others of such products. Nor is the information herein to be construed as absolutely complete, since additional information may be necessary or desirable when particular or exceptional conditions or circumstances exist or because of applicable laws or government regulations.

US
4-2017

Pressure Tactics

Tubular backwashing systems save you time and money compared with disposable media systems. The permanent media of Eaton's AFR, AFC, and F-Series systems is "cleaned-in-place" using reverse flow technology. System maintenance is significantly reduced and the cost of landfill disposal is eliminated.

How the AFR-Series Works

The simple, space-saving design of the AFR-Series – with only a single moving part – is ideal for the most demanding applications. The unit features a circular configuration of up to 8 tubes surrounding a central cleaning valve. During the filtration phase, filtrate travels from the inlet (1) to the diverter chamber (2) and up into the filter tubes (3). Cleaned liquids flow to the upper chamber (4) and out the large outlet near the top of the unit (5).

All tubes can be in filtration mode or the diverter mechanism can be rotated so that each individual tube (6) can be backwashed while the others remain in filtration mode.

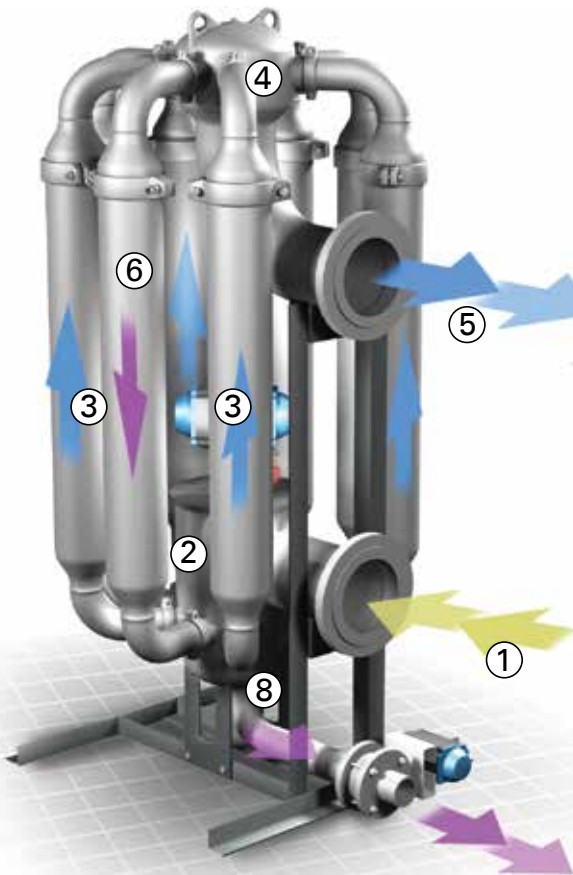

During backwash, a diverter (7) inside the cleaning valve rotates to the tube to be cleaned. This closes the tube to the incoming process liquid and opens it to the atmosphere via the drain line (8). The result causes outlet process liquid to flow in reverse through the element, cleaning it of contaminants and expelling them through the drain (8).

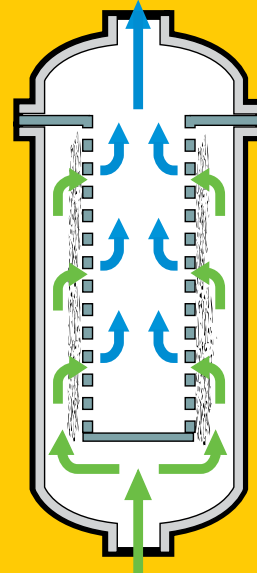
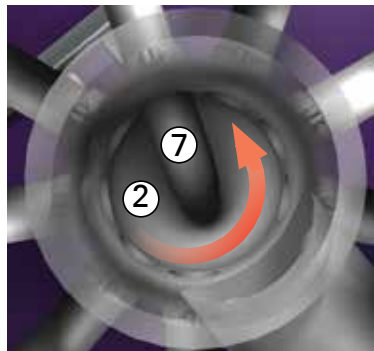

Filtration Cycle

Contaminated material flows up the outside of the filter tubes, through the filter media, and the cleaned fluid is expelled to the top from inside the tube. Debris collects on the outside surface of the screen forming a cake, which facilitates efficient filtration.

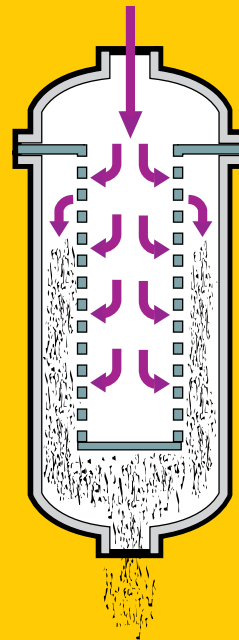

Backwashing Cycle

During backwash, triggered by time or pressure differential, the direction of the flow is reversed in the filter tube causing contaminants on the media surface to become dislodged and allowing them to be purged downward and out the drain valve.



Powering Business Worldwide

TECHNICAL INFORMATION

Tubular Backwashing Systems



With an internal backwashing system, a small amount of clean process liquid flows backward through the tube being cleaned and out the drain header at the unit base.

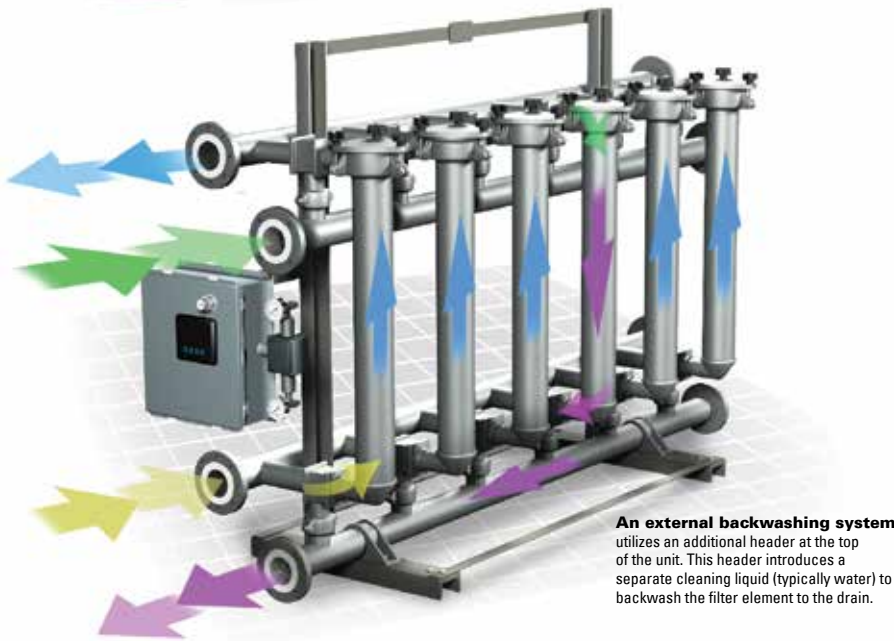

An external backwashing system utilizes an additional header at the top of the unit. This header introduces a separate cleaning liquid (typically water) to backwash the filter element to the drain.

F-Series and AFC-Series

Eaton's F-Series and AFC-Series are designed for the best possible performance. During backwash, a single tube is taken off-line from the process flow via a three-way valve. Once an element is clean, it is returned to service and the next element may be cleaned. The remaining elements in the filter remain operational throughout this cycle. F-Series and AFC-Series multiplex units consist of 2-20 individual tubes valved in parallel to common inlet, outlet, and drain headers. AFC-Series units are also available in economical single and duo tube configurations, which must be removed from service for manual cleaning.

Internal and external backwashing configurations

Eaton's F-Series and AFC-Series tubular multiplex systems are available in both internal and external backwashing configurations. Internal backwashing systems are designed for processes with system pressure greater than or equal to 45 psi (3.1 bar) and low viscosity process liquids. External backwashing systems are designed for applications with high-value process liquids and/or processes with low operating pressures.

System control

Designed to monitor and operate the backwash cleaning system, Eaton automatic control systems are simple to operate, reliable, and easily maintained. They are set to clean on differential pressure with a timed backup. The design allows field adjustments to suit the demands of the service conditions, ensuring effective cleaning with a minimum use of backwash fluid. Systems are available in automatic intermittent or continuous backwashing modes.



North America
44 Apple Street
Tinton Falls, NJ 07724
Toll Free: 800 656-3344
(North America only)
Tel: +1 732 212-4700

China
No. 3, Lane 280,
Linhong Road
Changning District, 200335
Shanghai, P.R. China
Tel: +86 21 5200-0099

Europe/Africa/Middle East
Auf der Heide 2
53947 Nettersheim, Germany
Tel: +49 2486 809-0

Singapore
4 Loyang Lane #04-01/02
Singapore 508914
Tel: +65 6825-1668

Friedensstraße 41
68804 Altlußheim, Germany
Tel: +49 6205 2094-0
An den Nahewiesen 24
55450 Langenlonsheim, Germany
Tel: +49 6704 204-0

Brazil
Rua Clark, 2061 - Macuco
13279-400 - Valinhos, Brazil
Tel: +55 11 3616-8400

Mechanically Cleaned Filters and Strainers

DCF, MCF, MCS

Unbeatable reliability
with measurable ROI

PERMANENT MEDIA WITH DISC CLEANING TECHNOLOGY

- Elimination or reduction in disposable filter bags or cartridges for reduced operator handling inventory costs and landfill waste
- Reduction in product loss, more thorough contaminant purge
- Reduction or elimination of operator intervention for safer operation
- Virtually maintenance free, near 100% uptime
- Compact design, lower capital cost to fit most installations
- Choice of pneumatic, motor drive or magnetic actuation
- Stainless steel screens from 15 micron slots to 1/4" perforations to handle a wide range of filtration needs
- Short payback period and increased ROI



Eaton's unique spring loaded cleaning disc (shown here in an MCS-500) ensures intimate contact with the filtration screen to thoroughly and uniformly clean the media.

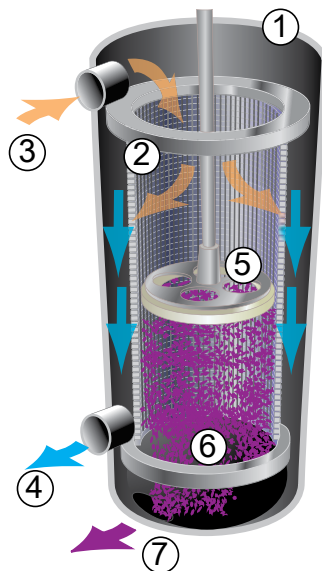

TYPICAL APPLICATIONS

- paper coatings • pcc/gcc slurries • phenolic resins • detergents
- petroleum based greases • ethanol processing • hot fry oils
- cip fluids (sodium hydroxide) • starch • lime slurries • adhesives
- curtain coaters • nutraceuticals • machining coolants • paint
- ink • chocolate • edible oils • tallow

Collect, concentrate, expel

Eaton's mechanically cleaned filters are based on a simple concept: A cylindrical stainless steel housing (1) contains a filter screen (2); unfiltered liquids enter the inlet (3); solids are deposited on the interior surface of the filtration screen; and filtered fluid exits at the outlet (4).

When the media requires cleaning (based on time, differential pressure, or manual selection), a spring loaded cleaning disc travels down and up, wiping the media clean of concentrated solids in both strokes. Once the debris is removed from the slotted screen, the cleaning disc directs the contaminant to the bottom of the housing (6) and out of the flow path (7). This cleaning process happens while the filter remains in service, thereby maintaining process efficiency and dramatically reducing loss of valuable product.

Choice of actuation method

Pneumatic -The cleaning disc can be actuated by air pressure alone (60 to 80 psi @ 5 cfm). DCF-800 and DCF-1600 models feature single or twin air cylinders. The smaller DCF-400 is equipped with a single cylinder.

Pneumatic with magnetic coupling - MCS and MCF-Series utilize rare earth magnets to eliminate the need for lid thru-holes and their associated seals. This cost-effective method reduces maintenance and lengthens operating life.

Motorized - The DCF-2000 Series uses a motor to drive the cleaning disc through higher viscosity fluids and other challenging conditions.

EATON

Powering Business Worldwide

Mechanically Cleaned Filters

DCF-Series

When processing water and water-like liquids where a low initial investment is demanded, this series delivers tremendous benefits.



DCF-1600



DCF-800



DCF-1600 with twin actuation



DCF-2000

DCF-2000 Series

Designed specifically for the needs of the pulp and paper industry, the DCF-2000 features a rugged motorized cleaning action, which can handle the continuous processing requirements of protecting critical wet-end coating operations.

High Flow MCS Strainer

Engineered to conserve valuable process water while protecting costly equipment from debris, the MCS features fast-cleaning magnetically coupled actuation. This high flow strainer uses a magnetically coupled cleaning disc, which eliminates the need for cover thru-holes and their associated seals.



MCS-500

MCF-824



MCF 824-Series

The MCF features a magnetically coupled cleaning disc, which eliminates the need for lid thru-holes and their associated seals. The MCF was designed specifically for the most challenging process liquids and conditions, and features the fastest cleaning action of the mechanically cleaned family.

	DCF-400	DCF-800	DCF-1600	DCF-2000	MCF-824	MCS-500	MCS-1500
Total Volumetric Capacity gal (liters)	0.94 (3.5)	3.9 (14.8)	11 (41.6)	11 (41.6)	11 (41.6)	18.7 (70.8)	49.2 (186.2)
Flow Rate Range at 100µ gpm (m³/hr)	2–20 (0.45–4.5)	20–60 (4.5–13.6)	60–200 (13.6–45.4)	30–200 (6.8–45.4)	30–200 (6.8–45.4)	to 500 (to 112.5)	to 1500 (to 337.5)

North America
44 Apple Street
Tinton Falls, NJ 07724
Toll Free: 800 656-3344
(North America only)
Tel: +1 732 212-4700

China
No. 3, Lane 280,
Linhong Road
Changning District, 200335
Shanghai, P.R. China
Tel: +86 21 5200-0099

Europe/Africa/Middle East
Auf der Heide 2
53947 Nettersheim, Germany
Tel: +49 2486 809-0

Singapore
4 Loyang Lane #04-01/02
Singapore 508914
Tel: +65 6825-1668

Friedensstraße 41
68804 Altlußheim, Germany
Tel: +49 6205 2094-0
An den Nahewiesen 24
55450 Langenlonsheim, Germany
Tel: +49 6704 204-0

Brazil
Rua Clark, 2061 - Macuco
13279-400 - Valinhos, Brazil
Tel: +55 11 3616-8400

Disc Cleaning Filters

DCF-400 DCF-800 DCF-1600

The Eaton DCF-Series is ideal for highly viscous, abrasive, or sticky liquids. The DCFs operate at a consistently low differential pressure and deliver simple, reliable operation in which a low initial investment is a key driving factor.

FEATURES

- Elimination or reduction in disposable filter bags and cartridges for reduced operator handling inventory costs and landfill waste
- Reduction in product loss, more thorough contaminant purge in a highly concentrated waste stream
- Reduction or elimination of operator intervention for safer operation
- Virtually maintenance free, near 100% uptime
- Compact design, lower capital cost to fit most installations
- Stainless steel screens from 15 micron slots to 1/4" perforations to handle a wide range of filtration needs
- Available with UHMWPE, Urethane®, Teflon, or Kynar® Cleaning Discs

TYPICAL APPLICATIONS

- paper coatings • pcc/gcc slurries • phenolic resins • detergents
- petroleum based greases • ethanol processing • hot fry oils
- cip fluids (sodium hydroxide) • starch • lime slurries • adhesives
- curtain coaters • nutricosmetics • machining coolants • paint
- ink • chocolate • edible oils • tallow

EATON

Powering Business Worldwide



DCF-400

DCF-800 - One actuator delivers simple, reliable operation with water-like liquids. Ideal where a low initial investment is a key driving factor

When processing water and water-like liquids where a low initial investment is demanded, DCF single actuator models deliver tremendous benefits. Available in 400, 800, and 1600 sizes, The DCF-Series enables operation at a vast range of flow rates and retentions.

The DCF-800 and DCF-1600 are also available in twin actuator models, which are designed for the rigors of processing highly viscous, abrasive, sticky, or otherwise hard-to-process liquids. DCF filters are suitable for a broad spectrum of challenging applications and accommodate a wide range of flow and retention requirements.

DCF-800 twin actuator model

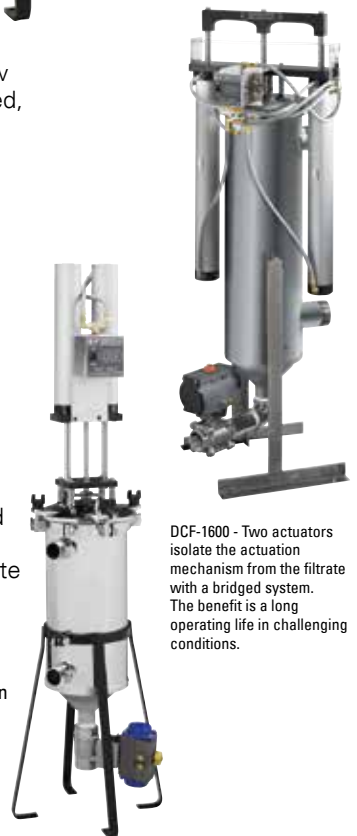

DCF-1600 - Two actuators isolate the actuation mechanism from the filtrate with a bridged system. The benefit is a long operating life in challenging conditions.



Our unique circular cleaning disc design (MCF design shown) ensures intimate contact with the screen to thoroughly and uniformly clean the media.

DCF-400, DCF-800, DCF-1600 Disc Cleaning Filters

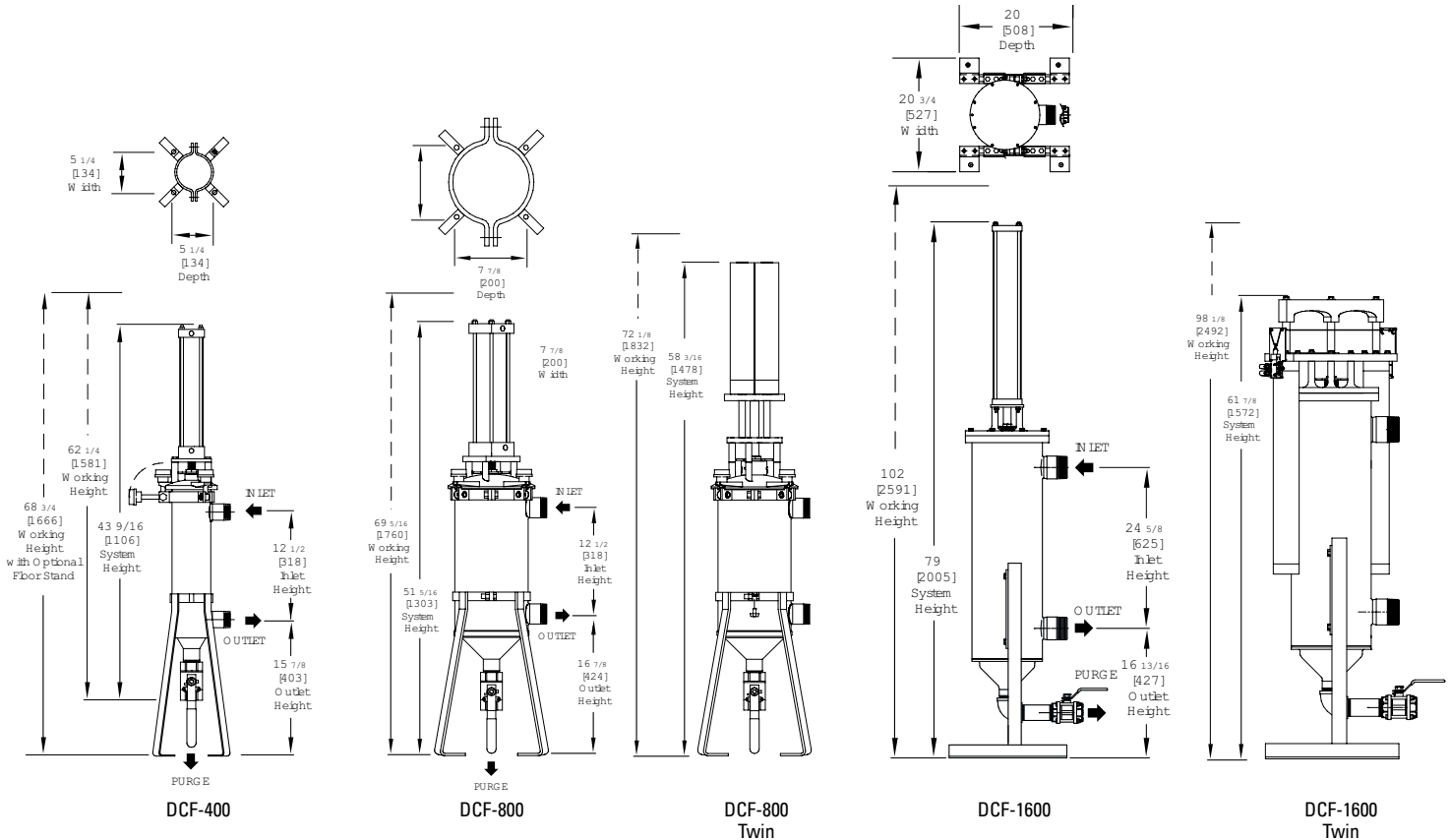

	DCF-400	DCF-800	DCF-1600
Single Unit Weight	35 lbs (16 kg)	75 lbs (34 kg)	215 lbs (97.5 kg)
Service Height	61.25 in (1556 mm)	69.25 in (1760 mm)	102 in (2591 mm)
Total Volumetric Capacity	0.94 gal (3.5 liters)	3.9 gal (14.8 liters)	11 gal (41.6 liters)
Purge Chamber Capacity	4 fl. oz (119 ml)	25 fl. oz (0.74 liters)	1.5 gal (6 liters)
Filtration Surface Area	112 in ² 722 cm ²	264 in ² 1703 cm ²	610 in ² 3935 cm ²
Flow Rate Range at 100µ	2–20 gpm 0.45–4.5 m ³ /hr	20–60 gpm 4.5–13.6 m ³ /hr	60–200 gpm 13.6–45.4 m ³ /hr
Temperature, maximum*	350° F (177° C)	350° F (177° C)	350° F (177° C)
Pressure, maximum	300 psi (21 bar)	150 psi (10.5 bar) standard	150 psi (10.5 bar) standard
Service Requirements	Air for Actuator Drive, min 400/800 = 60 psi at 5 cfm (4 bar @ 8.5 m ³ /min) 1600 = 80 psi at 5 cfm (5 bar @ 8.5 m ³ /min)		
Electrical for Controllers	Control for all three models, automated only, 110/220V, 50/60 Hz, single phase		

* Dependent on elastomer seal selection.

North America
44 Apple Street
Tinton Falls, NJ 07724
Toll Free: 800 656-3344
(North America only)
Tel: +1 732 212-4700

China
No. 3, Lane 280,
Linhong Road
Changning District, 200335
Shanghai, P.R. China
Tel: +86 21 5200-0099

Europe/Africa/Middle East
Auf der Heide 2
53947 Nettersheim, Germany
Tel: +49 2486 809-0

Singapore
4 Loyang Lane #04-01/02
Singapore 508914
Tel: +65 6825-1668

Friedensstraße 41
68804 Altlußheim, Germany
Tel: +49 6205 2094-0
An den Nahewiesen 24
55450 Langenlonsheim, Germany
Tel: +49 6704 204-0

Brazil
Rua Clark, 2061 - Macuco
13279-400 - Valinhos, Brazil
Tel: +55 11 3616-8400

Disc Cleaning Filters

DCF-2000

Mechanically
Cleaned

Permanent
Media



DCF-2000
Single Configuration

Eaton's DCF-2000 is designed specifically to address the challenges associated with filtering coatings and slurries in the paper making industry. Eliminate paperbreaks or streaks, reduce the environmental impact, and maximize uptime and productivity—for high production volumes and consistent product quality.

FEATURES

- Filters 48-72% solids coatings at 75 micron retention—the tightest in the industry
- Continuously removes contaminants from the coating and efficiently evacuates collected contaminants while operating at a low, constant differential pressure
- Designed for continuous unattended operation—without the need for operator intervention
- Mechanically cleaned media eliminates replacement media cost and the expense and hazard of waste disposal
- Increased profitability—improves system efficiency, reduces paperbreaks and associated downtime
- Multiplex configurations available and valved to a common tapered header for high-flow applications

TYPICAL APPLICATIONS

- paper coatings

DCF-2000

With a rugged motorized cleaning action, the DCF-2000 can handle the continuous processing requirements of protecting critical wet-end coating operations.



DCF-2000
Multiplex Configuration

EATON

Powering Business Worldwide

DCF-2000 Disc Cleaning Filters

Driven at a constant rate and pressure, the cleaning disc continuously wipes collected debris from the screen. Collected contaminants are agitated in the collection chamber, keeping them in a semi-liquid state, ready to be purged from the system.

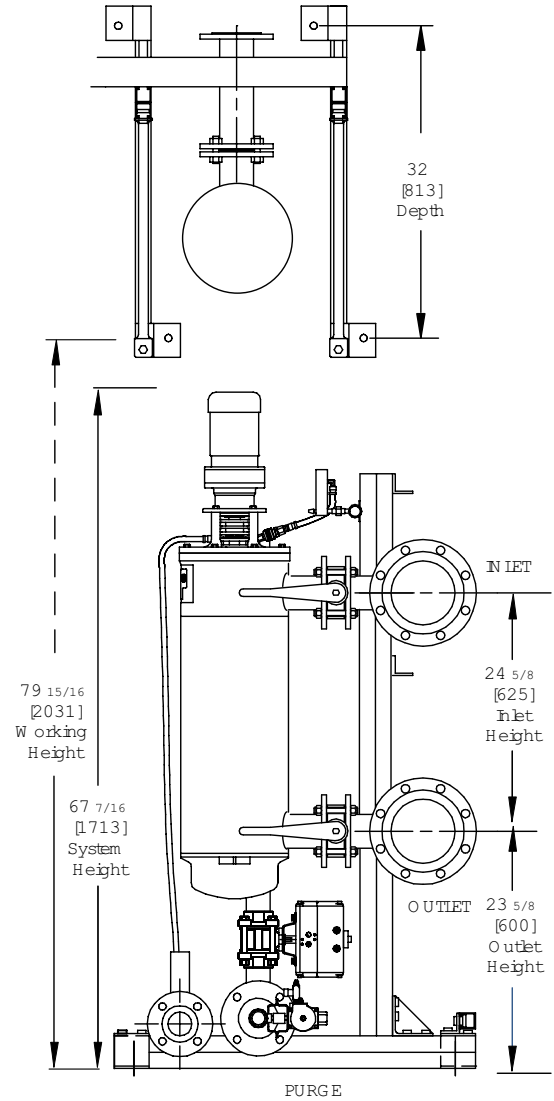
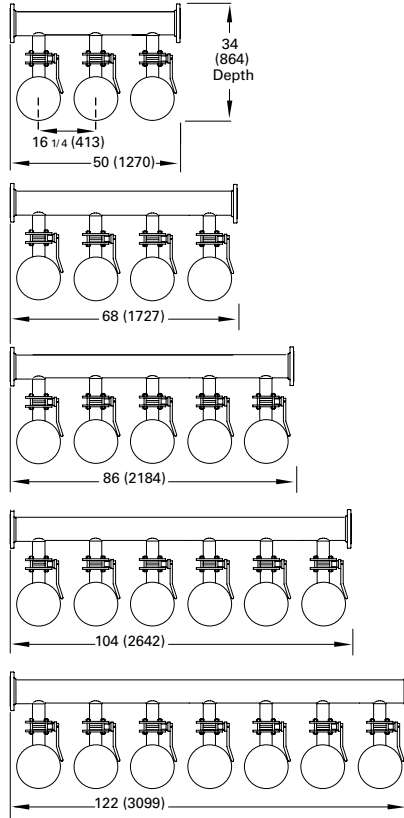
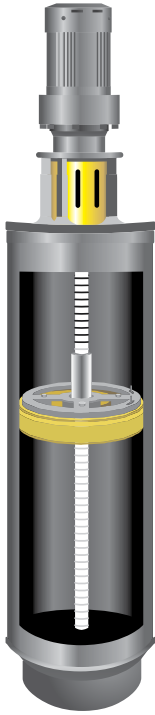

DCF-2000 Specifications

Single Unit Weight	564 lbs (256 kg)
Service Height	72 in (1829 mm)
Total Volumetric Capacity	11 gal (41.6 liters)
Purge Chamber Capacity	1.5 gal (6 liters)
Filtration Surface Area	610 in ² (3935 cm ²)
Flow Rate Range at 100µ	30–200 gpm 6.8–45.4 m ³ /hr
Temperature, maximum*	160° F (71° C)
Pressure, maximum	150 psi (10.5 bar) standard
Electrical for Motor Drive	single phase 110/220V, 50/60 Hz for control and three phase, 220/380/440/575V (please specify), 50/60 Hz for motor.
Electrical for Controllers	single phase 110/220V, 50/60 Hz

* Dependent on elastomer seal selection

North America
44 Apple Street
Tinton Falls, NJ 07724
Toll Free: 800 656-3344
(North America only)
Tel: +1 732 212-4700

China
No. 3, Lane 280,
Linhong Road
Changning District, 200335
Shanghai, P.R. China
Tel: +86 21 5200-0099

Europe/Africa/Middle East
Auf der Heide 2
53947 Nettersheim, Germany
Tel: +49 2486 809-0

Singapore
4 Loyang Lane #04-01/02
Singapore 508914
Tel: +65 6825-1668

Friedensstraße 41
68804 Altlußheim, Germany
Tel: +49 6205 2094-0

Brazil
Rua Clark, 2061 - Macuco
13279-400 - Valinhos, Brazil
Tel: +55 11 3616-8400

An den Nahewiesen 24
55450 Langenlonsheim, Germany
Tel: +49 6704 204-0



Powering Business Worldwide

For more information, please email us at filtration@eaton.com or visit www.eaton.com/filtration

© 2017 Eaton. All rights reserved. All trademarks and registered trademarks are the property of their respective owners. All information and recommendations appearing in this brochure concerning the use of products described herein are based on tests believed to be reliable. However, it is the user's responsibility to determine the suitability for his own use of such products. Since the actual use by others is beyond our control, no guarantee, expressed or implied, is made by Eaton as to the effects of such use or the results to be obtained. Eaton assumes no liability arising out of the use by others of such products. Nor is the information herein to be construed as absolutely complete, since additional information may be necessary or desirable when particular or exceptional conditions or circumstances exist or because of applicable laws or government regulations.

US
4-2017

Magnetically Coupled Filter

MCF

824-Series

Mechanically Cleaned
Permanent Media



Simplified design uses only 25 total parts

Up to 200 GPM throughput with virtually no downtime with the MCF 824-Series magnetically coupled self-cleaning filter. This technology allows for quick and easy access for maintenance, reduces potential leaks, and requires few moving parts while providing a long service life.

FEATURES

- Permanent media retains valuable product otherwise lost by media changeout
- Simple design with very few wear parts—for reduced spare parts stocking needs
- No external shaft or drive seals—eliminates all associated leakage
- Cleanable permanent media eliminates downtime and disposal requirements
- Easy no-tools access for routine maintenance and service
- Continuous operation—even during cleaning cycles

TYPICAL APPLICATIONS

- paper coatings • pcc/gcc slurries • phenolic resins • petroleum based greases • ethanol processing
- cip fluids (sodium hydroxide) • hot fry oils • starch • lime slurries • curtain coaters • nutraceuticals
- machining coolants • adhesives • paint • ink • chocolate • edible oils • detergents • tallow

OPTIONS

- EPT/EPDM (Nordel™) or Viton® seal material
- Advanced programmable microprocessors
- ASME code and CRN design units
- Automatic pressure transmitters
- Purge welding, internal and external polishing
- Multi-station configurations
- Air bleed capability

The MCF, from Eaton, draws upon our rich history of self-cleaning filtration. The innovative, magnetically coupled drive technology that moves the cleaning disc—without the need for shaft or drive external seals—makes the MCF unique. The MCF, a cost effective solution, is designed for a wide range of industrial liquid filtration applications. It also addresses the challenges of environmental concerns, loss of valuable product, and demand for greater operator safety.

How the MCF works

Filtrate flows from the top down and from the inside of the media toward the outside to increase retention of contaminants. The unique design uses a spring loaded cleaning disc that travels top to bottom inside the filter media – removing collected contaminants. The cleaning disc and flow continually drive undesirable solids downward, where they are concentrated in the purging chamber for easy expulsion. A hollow shaft at the center of the system contains a piston with powerful rare earth magnets. These internal magnets are coupled to external magnets housed in a carrier connected to the cleaning disc.

Pneumatic actuation moves the inner magnet up and down the shaft, with the outer magnet on the cleaning disc following. The result is powerful actuation, without the need for a physical linkage passing through the vessel.

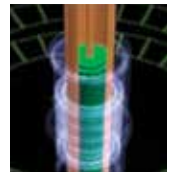

EATON

Powering Business Worldwide

MCF 824-Series Magnetically Coupled Filter

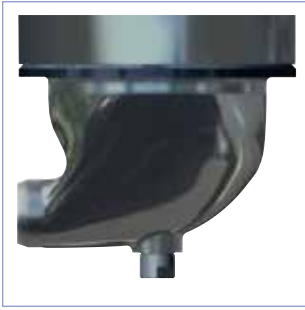

The MCF purge chamber was engineered without horizontal surfaces to facilitate flow dynamics for an extremely thorough purging process



Choice of stainless steel filters include wedge wire, rated from 15 – 1125 microns or perforated screens for complete removal of large solids



Quartered spring loaded cleaning disc combines maximum wear characteristics with optimized cleaning ability

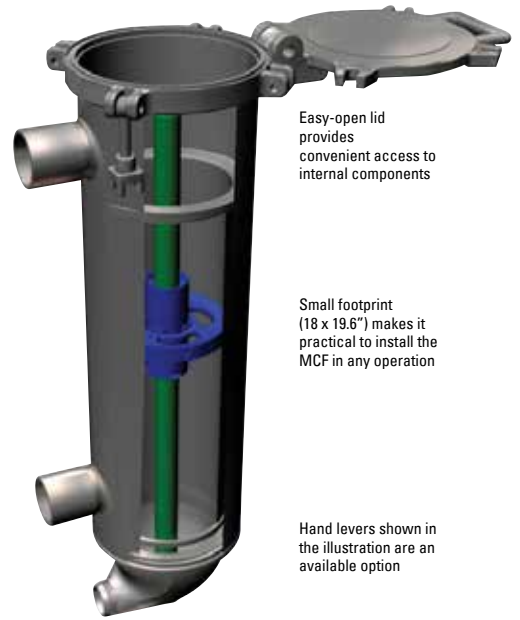

Easy-open lid provides convenient access to internal components

Small footprint (18 x 19.6") makes it practical to install the MCF in any operation

Hand levers shown in the illustration are an available option

MCF-824 STANDARD SPECIFICATIONS

Single Unit Weight	200 lbs (91 kg)
Service Height	64 in. (1,626 mm)
Footprint	19.6 in. (498 mm) x 18 in. (457 mm)
Volumetric Capacity	11 gal (41.6 l) total
Purge Chamber	1.3 gal (5 l) capacity
Connections: Standard	3 in (75 mm) I/O NPT thread, 2 in (50 mm) NPT1 purge
Connections: Optional	150# RFSO flanged, Sanitary, DIN (PM16) flanged, or BSPT—and purge valve options and more
Filtration Surface Area	601 in ² (3935 cm ²)
Media	Wedge wire: 15µ–1125µ, or defined pore: 25µ–100µ
Screen	Diameter: 8 in (203 mm), Length: 24 in. (610 mm), Area: 610in ² (3935 cm ²)
Flow Rate Range	30–200 gpm (6.8–45.4 m ³ /hr)
Temperature, maximum	180°F (82°C)
Operating pressure	30–150 psi (2–10.5 bar)
Elastomer Seal	Optional: EPT/EPDM (Nordel™) or Viton®
Cleaning Disc	Standard: Delrin - optional: High-Density Polyethylene
Housing/Wetted Parts Materials	Standard: 316 stainless steel
Controllers	Standard: continuous cleaning valve (CCV)
Controller Options	Push button, semi-automatic electric, electric timer, PLC
Air for Actuator Drive (Clean, dry, non lubricated air)	80 psi (5.5 bar) at 5 cfm (140 m ³ /m).
Electrical for Controllers (if equipped with optional electric automatic control timer):	110 or 220 Volt, 50 or 60 Hz, single-phase

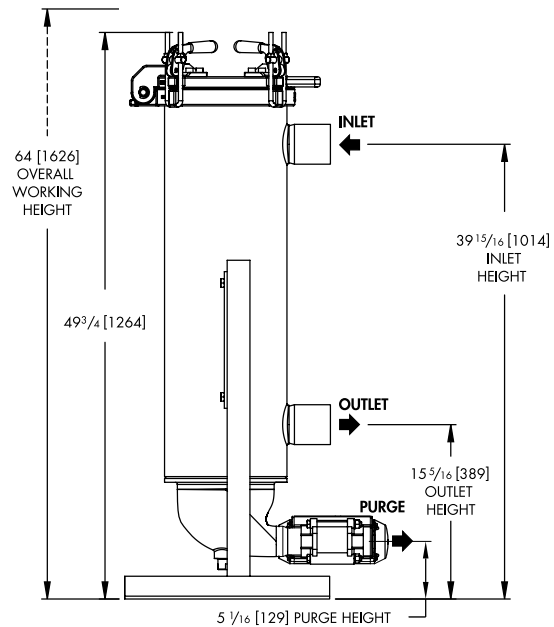

North America
44 Apple Street
Tinton Falls, NJ 07724
Toll Free: 800 656-3344
(North America only)
Tel: +1 732 212-4700

Europe/Africa/Middle East
Auf der Heide 2
53947 Nettersheim, Germany
Tel: +49 6205 2094-0

Friedensstraße 41
68804 Altlußheim, Germany
Tel: +49 6205 2094-0

An den Nahewiesen 24
55450 Langenlonsheim, Germany
Tel: +49 6704 204-0

China
No. 3, Lane 280,
Linhong Road
Changning District, 200335
Shanghai, P.R. China
Tel: +86 21 5200-0099

Singapore
4 Loyang Lane #04-01/02
Singapore 508914
Tel: +65 6825-1668

Brazil
Rua Clark, 2061 - Macuco
13279-400 - Valinhos, Brazil
Tel: +55 11 3616-8400

For more information, please email us at filtration@eaton.com or visit www.eaton.com/filtration

© 2017 Eaton. All rights reserved. All trademarks and registered trademarks are the property of their respective owners. All information and recommendations appearing in this brochure concerning the use of products described herein are based on tests believed to be reliable. However, it is the user's responsibility to determine the suitability for his own use of such products. Since the actual use by others is beyond our control, no guarantee, expressed or implied, is made by Eaton as to the effects of such use or the results to be obtained. Eaton assumes no liability arising out of the use by others of such products. Nor is the information herein to be construed as absolutely complete, since additional information may be necessary or desirable when particular or exceptional conditions or circumstances exist or because of applicable laws or government regulations.

US
4-2017



Powering Business Worldwide

Magnetically Coupled Strainer

High Flow MCS-500

Mechanically
Cleaned
Permanent
Media

The MCS-500's magnetically coupled actuation eliminates the need for dynamic seals. This technology provides quick and easy access for maintenance, reduces potential leaks, and requires few moving parts while providing a long service life.



Environmentally Sustainable Design

FEATURES

- No dynamic seals
- Minimal purge for low waste operation
- Easy in-line installation
- Continuous 24/7 operation
- Maintenance-friendly design means lower labor costs
- Eco-friendly. No bags to purchase, change, or landfill
- 316 stainless steel vessel

OPTIONS

- Multi-station configuration
- EPT/EPDM (Nordel™) or Viton® seal material
- Advanced programmable microprocessors
- ASME Code units
- Automatic pressure transmitters
- Purge welding
- Air bleed capability
- 304 stainless steel controller enclosure
- Gauge ports: 1/4"

The MCS-Series is engineered to conserve valuable process water while protecting costly equipment from debris. It offers minimal purge volumes in fresh water applications—allowing you to save on the cost of make up liquids, chemical treatment, and heating energy.

Featuring fast cleaning magnetically coupled actuation, this design offers an optimized configuration to help improve and reduce costly maintenance and downtime. In addition, this actuation method eliminates the need for cover thru-holes and their associated seals.

TYPICAL APPLICATIONS

- paper coatings • pcc/gcc slurries • phenolic resins • petroleum based greases • ethanol processing
- cip fluids (sodium hydroxide) • hot fry oils • starch • lime slurries • curtain coaters • nutraceuticals
- machining coolants • adhesives • paint • ink • chocolate • edible oils • detergents • tallow

EATON

Powering Business Worldwide

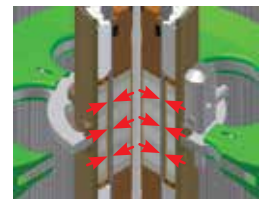

The actuation piston and cleaning disc are coupled by powerful rare earth magnets—a simple design that delivers tremendous benefits by eliminating the need for shaft or external drive seals.

MCS-500 Magnetically Coupled Strainer

HIGH FLOW MCS-500 SPECIFICATIONS

Approx Weight	350 lbs (159 kg)
Service Height	66 in (1676 mm)
Flow Rates at 100µ	Up to 500 gpm / 114 m ³ /hr
Operating Pressure	30-150 psi (2-10.5 bar)
Operating Temperature, max.	180° F (82° C)
Viscosity	Water/water-like fluids
Standard Retention*	150-1,100 microns
Vessel Material	316 Stainless Steel
Elastomers	EPT/EPDM (Nordel™) or Viton®
Process Connections	6 in 150# Flanged / DN 200 Flanged
Purge Connection	1 1/2 in NPT / 1 1/2 in BSPT
Air for Actuator Drive (Clean, dry, non lubricated air)	80 psi (5.5 bar) min - 116 psi (8 bar) max 5.0 cfm (141.5 L/min)
Electrical for Controllers	115 VAC or 230 VAC 50/60 Hz
Semi-Auto Voltage	24 VAC, 115 VAC, 230 VAC 24 VDC 115/230 VAC

*Tighter retentions available. Please call for more information.

MCS-500 Flow Rates

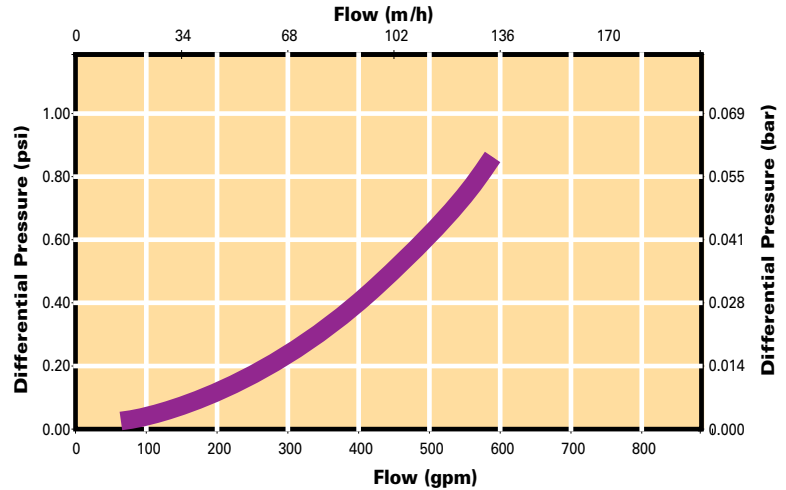

Up to eight MCS units can be configured into a multiplex system for high volume requirements

Slotted Wedge Wire Strainer Element Options

Inch	Micron	Mesh	% Open Area
.002	50	325	6
.003	75	200	9
.004	100	150	12
.006	150	100	17
.007	180	80	19
.008	200	70	21
.009	230	60	23
.015	380	40	33
.024	600	30	44
.030	700	20	50
.045	1140	15	60



Additional retentions available, consult Eaton.

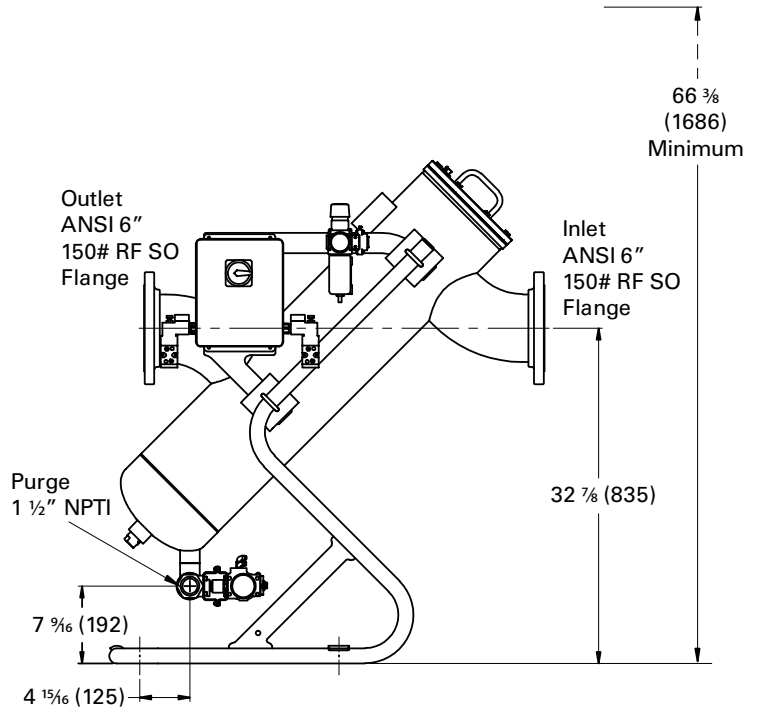

North America
44 Apple Street
Tinton Falls, NJ 07724
Toll Free: 800 656-3344
(North America only)
Tel: +1 732 212-4700

Europe/Africa/Middle East
Auf der Heide 2
53947 Nettersheim, Germany
Tel: +49 2486 809-0

Friedensstraße 41
68804 Altließheim, Germany
Tel: +49 6205 2094-0

An den Nahewiesen 24
55450 Langenlonsheim, Germany
Tel: +49 6704 204-0

China
No. 3, Lane 280,
Linhong Road
Changning District, 200335
Shanghai, P.R. China
Tel: +86 21 5200-0099

Singapore
4 Loyang Lane #04-01/02
Singapore 508914
Tel: +65 6825-1668

Brazil
Rua Clark, 2061 - Macuco
13279-400 - Valinhos, Brazil
Tel: +55 11 3616-8400

For more information, please email us at filtration@eaton.com or visit www.eaton.com/filtration

© 2017 Eaton. All rights reserved. All trademarks and registered trademarks are the property of their respective owners. All information and recommendations appearing in this brochure concerning the use of products described herein are based on tests believed to be reliable. However, it is the user's responsibility to determine the suitability for his own use of such products. Since the actual use by others is beyond our control, no guarantee, expressed or implied, is made by Eaton as to the effects of such use or the results to be obtained. Eaton assumes no liability arising out of the use by others of such products. Nor is the information herein to be construed as absolutely complete, since additional information may be necessary or desirable when particular or exceptional conditions or circumstances exist or because of applicable laws or government regulations.

US
4-2017

Magnetically Coupled Strainer

High Flow MCS-1500

Mechanically
Cleaned
Permanent
Media

Environmentally Sustainable Design

Eaton's MCS-1500 is perfect for high-capacity straining needs. Its magnetically coupled actuation eliminates the need for dynamic seals. This technology provides quick and easy access for maintenance, reduces potential leaks, and requires few moving parts while providing a long service life.



FEATURES

- No dynamic seals
- Minimal purge for low waste operation
- Easy in-line installation
- Continuous 24/7 operation
- Maintenance-friendly design means lower labor costs
- Eco-friendly. No bags to purchase, change, or landfill
- 316 stainless steel vessel

OPTIONS

- Multi-station configuration
- EPT/EPDM (Nordel™) or Viton® seal material
- Advanced programmable microprocessors
- ASME Code units
- Automatic pressure transmitters
- Purge welding
- High pressure units
- Air bleed capability
- 304 stainless steel controller enclosure
- Gauge port: 1/4"

The MCS-Series is engineered to conserve valuable process water while protecting costly equipment from debris. It offers minimal purge volumes in fresh water applications, allowing you to save on the cost of make up liquids, chemical treatment and heating energy.

Featuring fast cleaning magnetically coupled actuation, this design offers an optimized configuration to help improve and reduce costly maintenance and downtime. In addition, this actuation method eliminates the need for cover thru-holes and their associated seals.

TYPICAL APPLICATIONS

- paper coatings • pcc/gcc slurries • phenolic resins • petroleum based greases • ethanol processing
- cip fluids (sodium hydroxide) • hot fry oils • starch • lime slurries • curtain coaters • nutraceuticals
- machining coolants • adhesives • paint • ink • chocolate • edible oils • detergents • tallow

EATON

Powering Business Worldwide

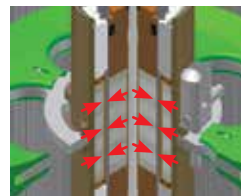

The actuation piston and cleaning disc are coupled by powerful rare earth magnets—a simple design that delivers tremendous benefits by eliminating the need for shaft or external drive seals.

MCS-1500 High Flow Magnetically Coupled Strainer



Up to eight MCS units can be configured into a multiplex system for high volume requirements.

Slotted Wedge Wire Strainer Element Options

Inch	Micron	Mesh	% Open Area
.002	50	325	6
.003	75	200	9
.004	100	150	12
.006	150	100	17
.007	180	80	19
.008	200	70	21
.009	230	60	23
.015	380	40	33
.024	600	30	44
.030	700	20	50
.045	1140	15	60



Additional retentions available, consult Eaton.

HIGH FLOW MCS-1500 SPECIFICATIONS

Approx Weight	775 lbs (352 kg)
Service Height	102 in (2591 mm)
Flow Rate Range at 100µ	Up to 1500 gpm / 340 m³/hr
Operating Temperature, max.	180° F (82° C)
Operating Pressure	30-150 psi (2-10.5 bar)
Viscosity	Water/water-like fluids
Standard Retention*	150-1,100 microns
Vessel Material	316 Stainless Steel
Elastomers	EPT/EPDM (Nordel™) or Viton®
Process Connections	8 in 150# Flanged / DN 200 Flanged
Purge Connection	2 in NPT / 2 in BSPT
Air for Actuator Drive (Clean dry non lubricated air)	80 psi (5.5 bar) min - 116 psi (8 bar) max 5.0 cfm (141.5 L/min)
Electrical for Controllers	115 VAC or 230 VAC 50/60 Hz
Semi-Auto Voltage	24 VAC, 115 VAC, 230 VAC 24 VDC 115/230 VAC

*Tighter retentions available. Please call for more information.

MCS-1500 Flow Rates

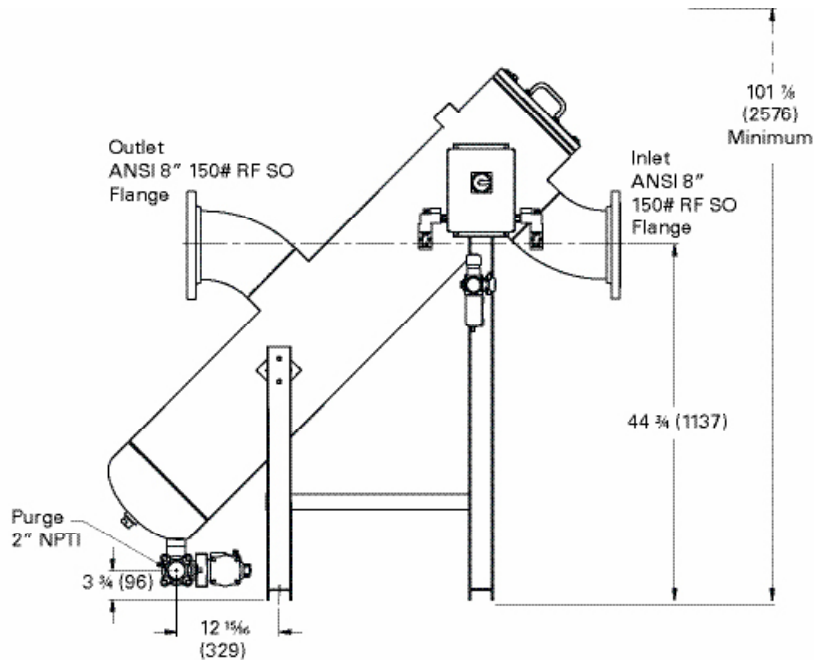
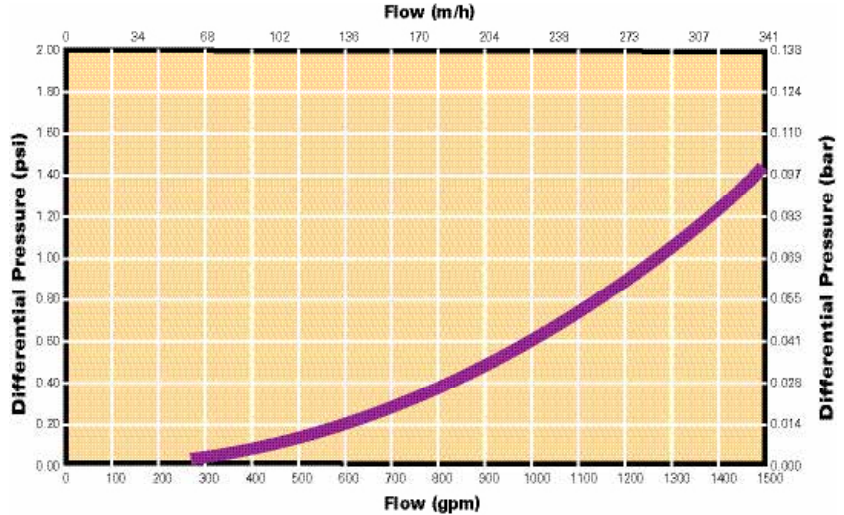

North America
44 Apple Street
Tinton Falls, NJ 07724
Toll Free: 800 656-3344
(North America only)
Tel: +1 732 212-4700

Europe/Africa/Middle East
Auf der Heide 2
53947 Nettersheim, Germany
Tel: +49 2486 809-0

Friedensstraße 41
68804 Altlußheim, Germany
Tel: +49 6205 2094-0

An den Nahewiesen 24
55450 Langenlonsheim, Germany
Tel: +49 6704 204-0

China
No. 3, Lane 280,
Linhong Road
Changning District, 200335
Shanghai, P.R. China
Tel: +86 21 5200-0099

Singapore
4 Loyang Lane #04-01/02
Singapore 508914
Tel: +65 6825-1668

Brazil
Rua Clark, 2061 - Macuco
13279-400 - Valinhos, Brazil
Tel: +55 11 3616-8400

**For more information, please
email us at filtration@eaton.com
or visit www.eaton.com/filtration**

© 2017 Eaton. All rights reserved. All trademarks and registered trademarks are the property of their respective owners. All information and recommendations appearing in this brochure concerning the use of products described herein are based on tests believed to be reliable. However, it is the user's responsibility to determine the suitability for his own use of such products. Since the actual use by others is beyond our control, no guarantee, expressed or implied, is made by Eaton as to the effects of such use or the results to be obtained. Eaton assumes no liability arising out of the use by others of such products. Nor is the information herein to be construed as absolutely complete, since additional information may be necessary or desirable when particular or exceptional conditions or circumstances exist or because of applicable laws or government regulations.

US
4-2017

Disc Power



Our unique circular cleaning disc design (MCF 824-Series design shown) ensures intimate contact with the screen to thoroughly and uniformly clean the media.

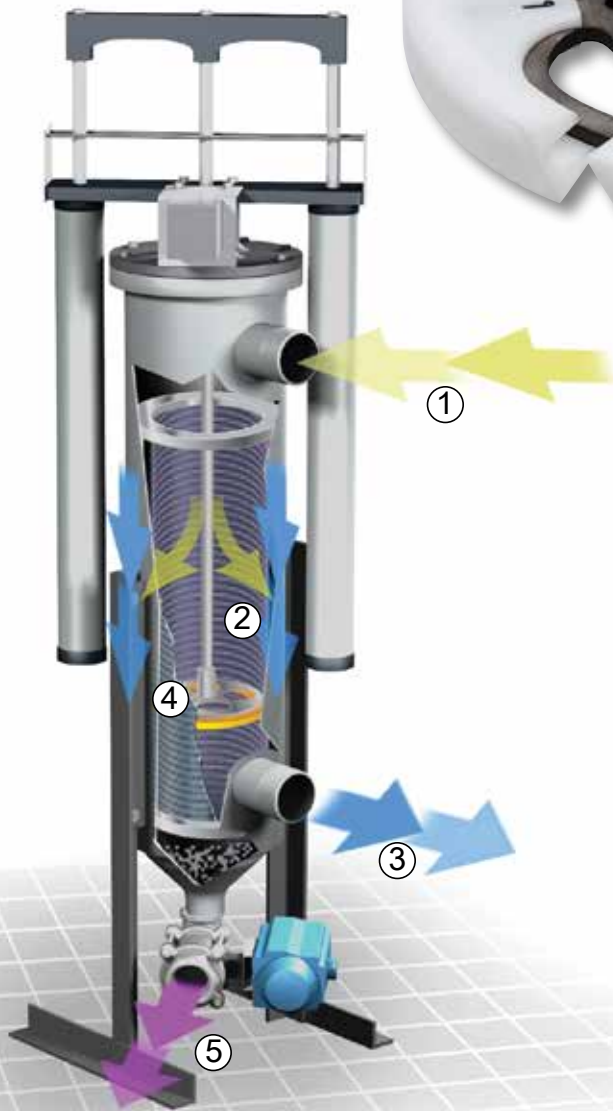

In Eaton's DCF mechanically cleaned filter unit, incoming fluids (1) are channeled from the interior cylinder through a wire screen (2) to the outer cylinder and out the discharge port (3). A cleaning disc (4) travels down and up inside the cylinder to periodically clear the filter screen. Particles are collected at the bottom of the housing where they can be discharged (5).

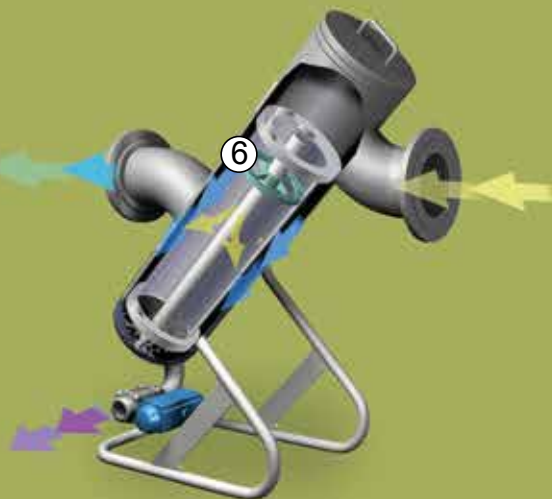

Eaton MCF and MCS operate in much the same manner as DCF units, but add the advantage of a magnetically coupled disc mechanism (6). This unique design eliminates the need for internal seals and reduces maintenance costs.



Powering Business Worldwide

TECHNICAL INFORMATION

Mechanically Cleaned Filters & Strainers



	DCF-400	DCF-800	DCF-1600	DCF-2000	MCF-824	MCS-500	MCS-1500
Approx Weight - lbs (kg)	35 (16)	75 (34)	215 (97.5)	564 (256)	200 (91)	350 (159)	775 (352)
Service Height - in (mm)	62 (1575)	69 (1753)	102 (2591)	80 (2032)	64 (1626)	66 (1676)	102 (2591)
Volumetric Capacity-gal (L)	0.94 (3.5)	3.9 (14.8)	11 (41.6)	11 (41.6)	11 (41.6)	18.7 (70.8)	49.2 (186.2)
Purge Chamber Capacity-gal (L)	0.0313 (0.119)	0.2 (0.74)	1.5 (6)	1.5 (6)	1.3 (5)	0.56 (2.1)	1.1 (4.1)
Filtration Surface Area - in ² (cm ²)	112 (722)	264 (1703)	610 (3935)	610 (3935)	610 (3935)	610 (3935)	1508 (9729)
Flow Rate Range at 100μ - gpm (m ³ /hr)	2–20 (0.45–4.5)	20–60 (4.5–13.6)	60–200 (13.6–45.4)	30–200 (6.8–45.4)	30–200 (6.8–45.4)	up to 500 (up to 114)	up to 1500 (up to 342)
Temp. max F (C)	350° (177°)	350° (177°)	350° (177°)	160° (71°)	180° (82°)	180° (82°)	180° (82°)
Pressure, max- psi (bar)	300 (21)	150 (10.5)	150 (10.5)	150 (10.5)	150 (10.5)	150 (10.5)	150 (10.5)

North America
 44 Apple Street
 Tinton Falls, NJ 07724
 Toll Free: 800 656-3344
 (North America only)
 Tel: +1 732 212-4700

China
 No. 3, Lane 280,
 Linhong Road
 Changning District, 200335
 Shanghai, P.R. China
 Tel: +86 21 5200-0099

Europe/Africa/Middle East
 Auf der Heide 2
 53947 Nettersheim, Germany
 Tel: +49 2486 809-0

Singapore
 4 Loyang Lane #04-01/02
 Singapore 508914
 Tel: +65 6825-1668

Friedensstraße 41
 68804 Altließheim, Germany
 Tel: +49 6205 2094-0
 An den Nahewiesen 24
 55450 Langenlonsheim, Germany
 Tel: +49 6704 204-0

Brazil
 Rua Clark, 2061 - Macuco
 13279-400 - Valinhos, Brazil
 Tel: +55 11 3616-8400

For more information, please email us at filtration@eaton.com or visit www.eaton.com/filtration

US
 4-2017

© 2017 Eaton. All rights reserved. All trademarks and registered trademarks are the property of their respective owners. All information and recommendations appearing in this brochure concerning the use of products described herein are based on tests believed to be reliable. However, it is the user's responsibility to determine the suitability for his own use of such products. Since the actual use by others is beyond our control, no guarantee, expressed or implied, is made by Eaton as to the effects of such use or the results to be obtained. Eaton assumes no liability arising out of the use by others of such products. Nor is the information herein to be construed as absolutely complete, since additional information may be necessary or desirable when particular or exceptional conditions or circumstances exist or because of applicable laws or government regulations.



Powering Business Worldwide

Cleanable Media and System Options

Selection of media retentions and degree of automation is easy with Eaton mechanically cleaned filtration systems. Choose from 15 micron filter elements to 1/4" strainers. Manual to semi-automatic to full microprocessor controlled systems can be configured to suit specific operations, and the range of internal and external components help make Eaton systems a logical choice for long-term efficiency and cost control.

A range of control systems can be employed to actuate and monitor mechanically cleaned systems. Microcomputer controls can also be integrated with system-wide operations.



MEDIA ELEMENTS



Slotted Wedge Wire
DCF/MCF/MCS filter screens feature special wedge wire that is honed perfectly circular to guarantee contact with the cleaning disc so the slot openings are smallest at the screen's surface. This design helps prevent particle plugging of the slot openings while assuring total rated solids removal.

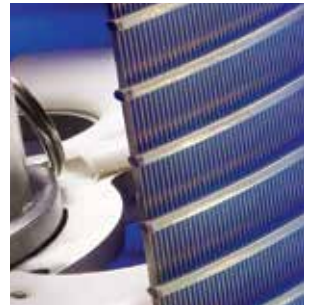

Perforated
Perforated screens feature precise and uniform perforation patterns for complete removal of larger solids. These elements are ideal for straining large volumes of viscous fluids. 1/16", 1/8", and 1/4" perforations are available.



Powering Business Worldwide

Mechanically Cleaned Filter Media and Options

MEDIA RETENTIONS

Slotted Wedge Wire

Inch	Micron	Mesh	% Open Area
.0006	15	—	2
.001	25	—	3
.0015	38	400	5
.002	50	325	6
.003	75	200	9
.004	100	150	12
.006	150	100	17
.007	180	80	19
.008	200	70	21
.009	230	60	23
.015	380	40	33
.024	600	30	44
.030	700	20	50
.045	1140	15	60

Perforated

Inch	Micron	Mesh	% Open Area
1/16	1575	12	40
1/8	3175	6	40
1/4	6360	3	57

Additional retentions available. Consult Eaton.

CONTROL SYSTEM CHOICES

The control options for mechanically cleaned filters are as broad as the applications they serve. Available controllers include:



PLC microcomputer controls deliver programmable stand-alone performance, or can integrate with control networks. Allen-Bradley and Siemens controls are standard PLC options.



Continuous Cleaning Valve (CCV) is the standard configuration where the cleaning disc continuously cycles, driven by shop airflow. Purge is controlled by a manual valve or push-button.



Electric timer for timed stroke (single) or stroke and purge (dual) in a NEMA 4-, 7-, or 12- rated enclosure. Dual pneumatic timers are available for explosion proof environments.



Semi-automatic electric control units for use with customer supplied controls for stroke and purge.

DISC AND SEAL CHOICES

To meet the widest range of operating conditions and process liquid characteristics, Eaton mechanically cleaned systems are available with a number of lid and element seal elastomers and cleaning discs.

Lid and element seals

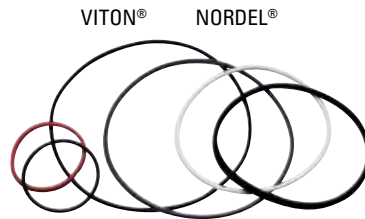

Cleaning discs



North America
44 Apple Street
Tinton Falls, NJ 07724
Toll Free: 800 656-3344
(North America only)
Tel: +1 732 212-4700

Europe/Africa/Middle East
Auf der Heide 2
53947 Nettersheim, Germany
Tel: +49 2486 809-0

Friedensstraße 41
68804 Altließheim, Germany
Tel: +49 6205 2094-0

An den Nahewiesen 24
55450 Langenlonsheim, Germany
Tel: +49 6704 204-0

China
No. 3, Lane 280,
Linhong Road
Changning District, 200335
Shanghai, P.R. China
Tel: +86 21 5200-0099

Singapore
4 Loyang Lane #04-01/02
Singapore 508914
Tel: +65 6825-1668

Brazil
Rua Clark, 2061 - Macuco
13279-400 - Valinhos, Brazil
Tel: +55 11 3616-8400

For more information, please email us at filtration@eaton.com or visit www.eaton.com/filtration

© 2017 Eaton. All rights reserved. All trademarks and registered trademarks are the property of their respective owners. All information and recommendations appearing in this brochure concerning the use of products described herein are based on tests believed to be reliable. However, it is the user's responsibility to determine the suitability for his own use of such products. Since the actual use by others is beyond our control, no guarantee, expressed or implied, is made by Eaton as to the effects of such use or the results to be obtained. Eaton assumes no liability arising out of the use by others of such products. Nor is the information herein to be construed as absolutely complete, since additional information may be necessary or desirable when particular or exceptional conditions or circumstances exist or because of applicable laws or government regulations.

US
4-2017

• Filtration • Strainers • Gas/Liquid Separation

Eaton Complete Family of Filtration Solutions

Bag and Cartridge Filtration Systems

Ideal for the removal of large amounts of very fine material from the process media.

- Single or multi-bag vessels in stainless steel, carbon steel, or corrosion-resistant plastic
- Choose from a huge selection of filter bags in a variety of materials and retentions
- High performance, cost-effective liquid process filter cartridges for common and difficult industrial applications



Mechanically Cleaned Filters

A sustainable solution for the automatic removal of debris from liquids with no bags to buy, change, or landfill.

- Tubular Backwashing
- Disc Cleaning
- Pneumatic, Motorized, or Magnetically Coupled Actuation



Standard Cast Pipeline Strainers

Protecting pumps, filters, nozzles, flowmeters, valves, heat exchangers, condensers, oil burners, boilers, and other process system components from damaging pipeline debris is what Eaton Pipeline Strainers do best.

- Heavy-duty Y Strainer
- Simplex Basket Strainers
- Duplex Basket Strainers



Mechanically Cleaned Strainers and Fabricated Pipeline Strainers

High-flow capabilities in hundreds of configurations and sizes.

- Sizes up to 60 inches
- Continuous Operation
- Motorized or Magnetically Coupled Actuation
- Custom designs and exotic materials of construction are available

Hydraulic and Lubrication Oil Filtration Systems

- 4000 different filter elements, including corresponding filter housings
- Condition Monitoring
- Hydraulic Filter Accessories



Depth Filtration

High-quality systems and media for the food and beverage, chemical, pharmaceutical and biotechnology industries.

- Depth Filter Sheets and Cartridges
- Stacked Disc Cartridges
- Filtration Systems
- Measuring and Testing Devices



Gas/Liquid Separators

Remove over 99% of moisture and particulate matter 10 microns and larger from air, gas, and steam lines.

An exclusive vortex containment plate (VCP) prevents re-entrainment and eliminates the need for complex baffles or deflectors. Offered in a variety of different models for application flexibility.



Powering Business Worldwide

SPECIALITY & CUSTOM SYSTEMS

In addition to our standard solutions, Eaton offers many industry specific filtration, strainer, and separation products with a proven record of accomplishment. Eaton engineers can customize and design modular solutions that provide a full range of retention capabilities and construction materials in manual and automated designs.



MEDIA OPTIONS

Eaton offers thousands of options for both disposable media systems and equipment that utilizes permanent filtration and strainer elements.

- Permanent media elements for self-cleaning filters and strainers
- Bag filters to fit a wide range of filter housings—with filtration efficiencies up to 99.98%
- Cartridge filters with a variety of retention ratings, sizes, end caps, material, and gaskets
- Depth filtration sheets for coarse, clarifying and fine filtration as well as microbe reduction and removal.



North America
44 Apple Street
Tinton Falls, NJ 07724
Toll Free: 800 656-3344
(North America only)
Tel: +1 732 212-4700

China
No. 3, Lane 280,
Linzhong Road
Changning District, 200335
Shanghai, P.R. China
Tel: +86 21 5200-0099

Europe/Africa/Middle East
Auf der Heide 2
53947 Nettersheim, Germany
Tel: +49 2486 809-0

Singapore
4 Loyang Lane #04-01/02
Singapore 508914
Tel: +65 6825-1668

Friedensstraße 41
68804 Altließheim, Germany
Tel: +49 6205 2094-0

Brazil
Rua Clark, 2061 - Macuco
13279-400 - Valinhos, Brazil
Tel: +55 11 3616-8400

An den Nahewiesen 24
55450 Langenlonsheim, Germany
Tel: +49 6704 204-0

**For more information, please
email us at filtration@eaton.com
or visit www.eaton.com/filtration**

© 2017 Eaton. All rights reserved. All trademarks and registered trademarks are the property of their respective owners. All information and recommendations appearing in this brochure concerning the use of products described herein are based on tests believed to be reliable. However, it is the user's responsibility to determine the suitability for his own use of such products. Since the actual use by others is beyond our control, no guarantee, expressed or implied, is made by Eaton as to the effects of such use or the results to be obtained. Eaton assumes no liability arising out of the use by others of such products. Nor is the information herein to be construed as absolutely complete, since additional information may be necessary or desirable when particular or exceptional conditions or circumstances exist or because of applicable laws or government regulations.